

**Guide Book for Practical Use of  
"Patent Map for Each Technology Field"**

**Japan Patent Office  
Asia-Pacific Industrial Property Center, JIPI**



# *Guide Book for Practical Use of "Patent Map for Each Technology Field"*

**Invention Research Institute  
Japan Institute of Invention and Innovation**

## **Contents**

I. What is "Patent Map for Each Technology Field"?	
1. Purpose of " Patent Map for Each Technology Field"	3
2. Production of " Patent Map for Each Technology Field"	4
3. Composition of " Patent Map for Each Technology Field"	4
II. How to Use "Patent Map for Each Technology Field"	6
1. To Understand the Overall State of a Technology Field	7
(1) Maps Portraying an Overall Composition of a Technology Field or an Expanse of a Technology Field	7
(2) Map Portraying Expanses of Applications of a Technology Field	8
(3) Map Portraying Technology Fields Related to a Technology Field	10
(4) Map Portraying a Technological Progress	12
2. To Find out Technological Changes	14
(1) Map Portraying Changes of Relations between Activity of a Technology Development and Participating Companies	14
(2) Map Portraying the Degree of Maturity of a Technology Field	15
(3) Map Portraying Changes of Technical Contents	17
(4) Map Portraying Trends of Problems in a Technological Development	18
(5) Map Portraying Changes of Influential Industrial Field in Technological Development	19
(6) Map Portraying a Technological Development	20

3. To Seek Business Opportunities	21
(1) Map Portraying the Status Quo of Applications with Multiple Perspective of a Technology Field	21
(2) Maps Portraying Problems in a Technological Development	24
(3) Map Portraying Correspondence between Problems and Technologies	27
4. To Know Properties of Applicants	28
(1) Map Portraying Applicants Having Having Filed Many Applications	28
(2) Map Portraying Types of Applicants (Individuals, Companies, Government Offices, etc.)	30
(3) Map Portraying Numbers of Applications According to the Nationalities of Applicants	31
(4) Map Portraying Composition of Applications by Industry Type	32
5. To Deal with the Globalization of Business	33
(1) Map Portraying Structural Differences of Applications among the US, Europe and Japan	34
(2) Map Portraying Upper Ranked Applicants (Right Holders) of Foreign Countries	35
(3) Map Portraying Expanses of a Technology Development in Foreign Countries	35
6. Examples of Combination of Patent Maps	38
III. The Patent Maps Produced by Technology Field	45
 Glossary of Terms	

## **I. What is "Patent Map for Each Technology Field"?**

### **1. Purpose of "Patent Map for Each Technology Field" —**

Current technological development necessitates conducting searches of patent information to avoid unnecessary investment as well as gaining the seeds for technological development and the applicable fields contained in the patent information. In order to accomplish this, visual representation of related patent information (hereinafter "Patent Map") attracts the attention of the persons concerned. A patent map is produced by gathering related patent information of a target technology field, processing, and analyzing it.

Also, in order to promote the use of patents, it is necessary for related institutions to deepen their understanding of patent information and strive to achieve efficient use of the information. The effectiveness of patent maps has also attracted attention with respect to this point as well.

However, since experts are required for the gathering of patent information etc. and analyzing, it is not always easy for the production of patent maps to be carried out by venture companies, small and medium sized companies or universities and other research institutions on their own because they are unable to sufficiently invest human resources, economic resources and time.

On the basis of this awareness, the Japan Patent Office has been producing and providing patent maps for several technology fields for the purpose of being of assistance in utilizing patent information in industry since 1997.\*

---

\* III. The Patent Maps Produced by Technology Field

## **2. Production of "Patent Map for Each Technology Field"** ---

The production of patent maps is conducted in the form of a joint project by experts on patent information analysis and specialists on each technology field. Twenty to thirty thousand patents are extracted for each technology field then analyzed using various methods in order to perform this work.

## **3. Composition of "Patent Maps for Each Technology Field"** ---

### Introduction

The overall image of a title technology field, relevant technology classification (categories), structures for related proliferating technology, comparisons between US and Japanese patents, structures of patent rights are introduced.

### Chapter 1 - Technology trends viewed from patents

To serve as a technical guide from the aspects of seed and need, technology classification based on specific patents, technology development patterns, status of inter-technologies relations, status of proliferation of technology development, and various theories in major fields are provided.

### Chapter 2 - Problems and development of technology

To serve as a guide based on actual technologies, the positioning of selected patents in terms of technology classification along with their rights status, the development of rights in major fields, the hierarchical structure from basic patents and the matrix of rights of major technologies are provided.

### Chapter 3 - Access to patent information and patent transfer information

Patent information has the three characteristics of "patent right information function", "technical information function" and "patent owner information function". Methods for effectively using this information are provided. More specifically, these consist of information about Industrial Property Digital

Library \*, patent information retrieval facilities and search tools relating to the technology field (IPC \*, FI \*, F term \*).

#### Chapter 4 - Overview of technology

Technical information necessary for understanding the relevant technology field is provided. For example, the explanations from the viewpoint of “what the technology field is” and “what it is used for”, as well as the history of that technology field along with the explanation of related technical terms are provided.

#### Reference Section

The method in which figure and table data used in the title technology field are prepared based on patent classifications, and to search formulas so as to allow confirmation and follow-up searches in the case readers attempt to produce their own maps. When the latest data is desired, the reader can search patent information by using the search formula.

---

\* III. "Glossary of Terms"

## II. How to Use " Patent Maps for Each Technology Field"

Patent maps are not only produced for a specific use, but also are produced to serve as so-called general-purpose use. Consequently, when using them, their contents can be read from various viewpoints. In particular, by combining multiple maps (figures and tables), it is possible to find a new matter that cannot be obtained from a single map.

In addition, a total of more than 50 types of expressions, excluding minor ones, are used in this patent map series. Furthermore, total more than 200 maps were produced in terms of their technology fields.

The readers can grasp various kind of matters from these patent maps according to their objective and intention.

In the following section, readers will be able to understand typical objectives of patent map and various representational types of patent map as well as the matters that can be extracted from these patent maps.

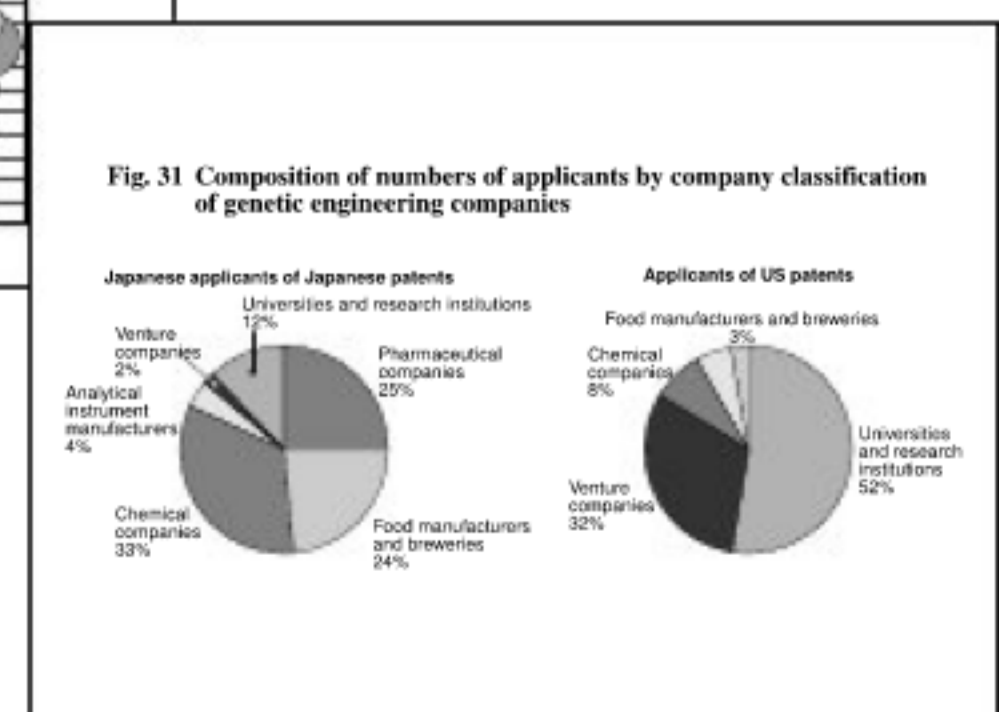
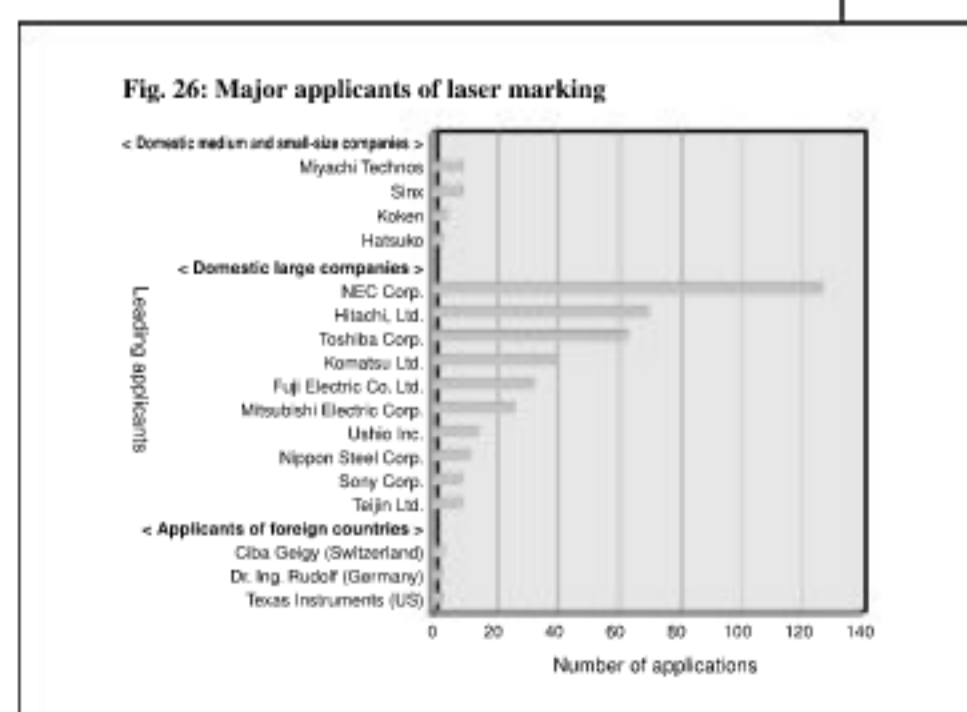
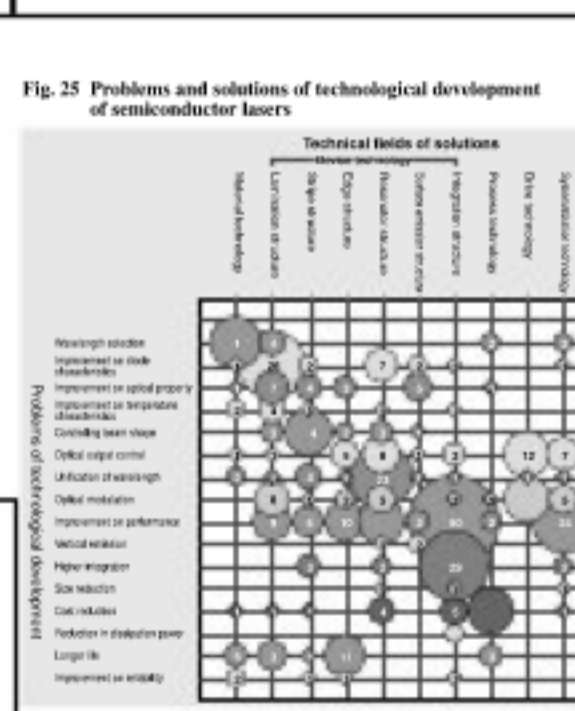
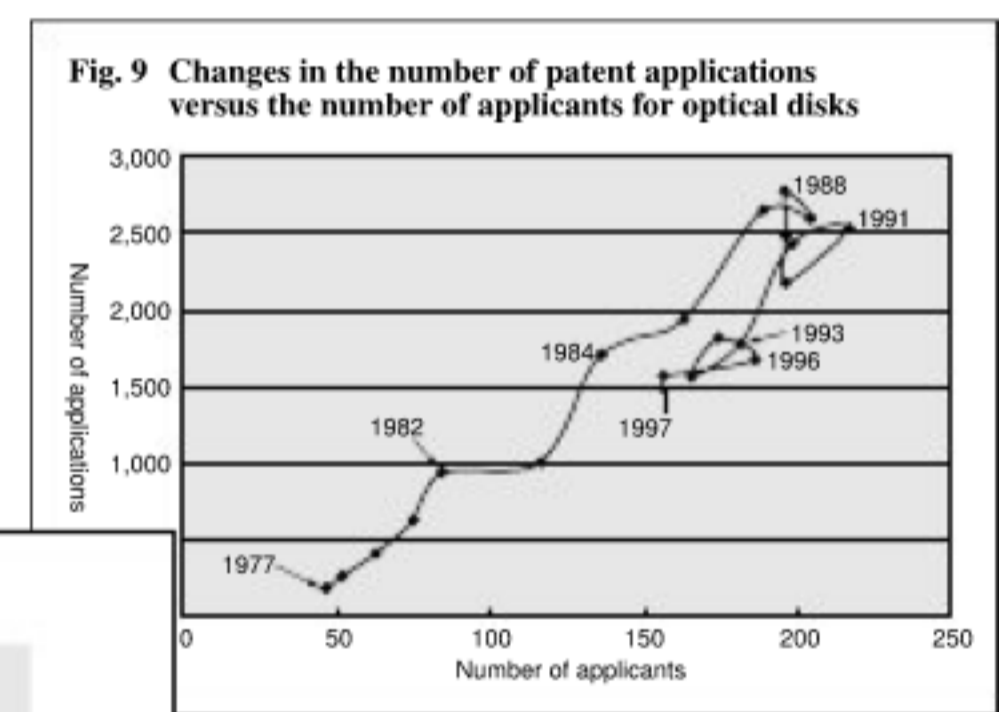
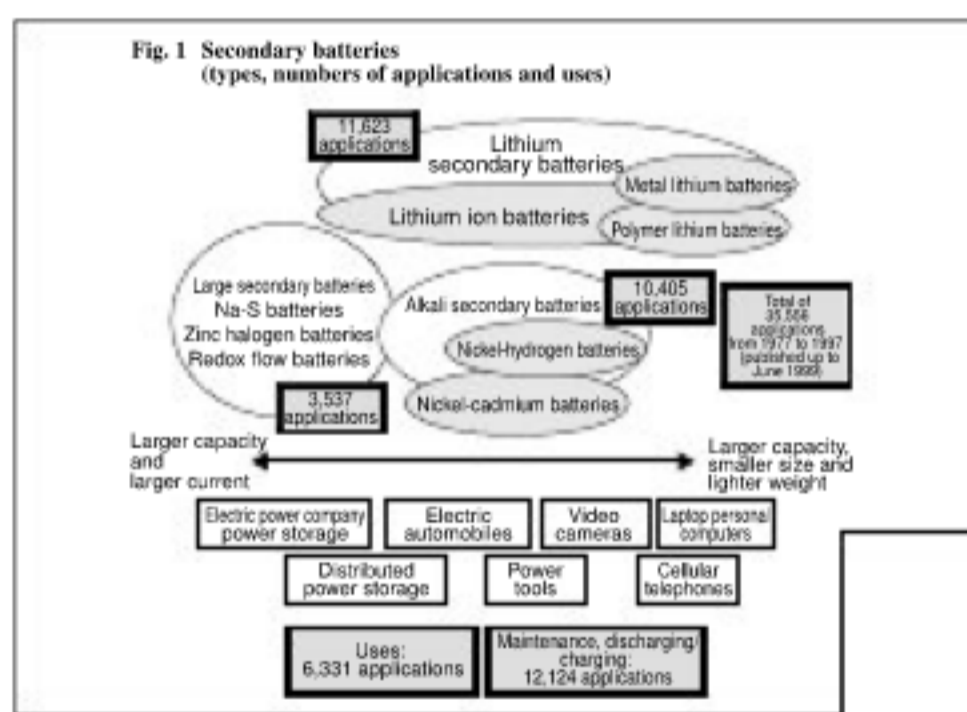



## **1. To Understand the Overall State of a Technology Field–**

When a company start a research and development or licensing for entering into a new business of a certain technology field, the company need to seize the overall image of the technology field and the related technology fields including pertinent patents.

Patent maps of a technology field introduce the content and number to which patents have been filed for the field, the uses in which the technology field is being used and the theme related to research and development of the field. The following shows the typical expressions of patent maps used for these purposes.

### **(1) Maps Portraying an Overall Composition of a Technology Field or an Expanse of a Technology Field**

There is a patent map showing an overall image of a technology field by illustration. This map is produced by classifying the patents of the technology field, picking up important patents, counting the number of patent applications, etc. As a result, the technology field can be understood systematically, making it possible to understand the distribution of the rights.

#### **Case 1: Secondary batteries (types, numbers of applications and uses) (Fig. 1)**

Fig. 1 shows an overview of the types of secondary batteries and uses coming from the characteristics of these batteries.

On the basis of this map, it can be seen that approximately 22,200, 6,300 and 12,100 applications were filed for secondary batteries themselves, uses and maintenance/discharging/charging, respectively.

In addition, it can also be seen that secondary batteries are divided into three groups. The largest number of applications were filed for lithium secondary batteries (including

**Fig. 1 Secondary batteries (types, numbers of applications and uses)**

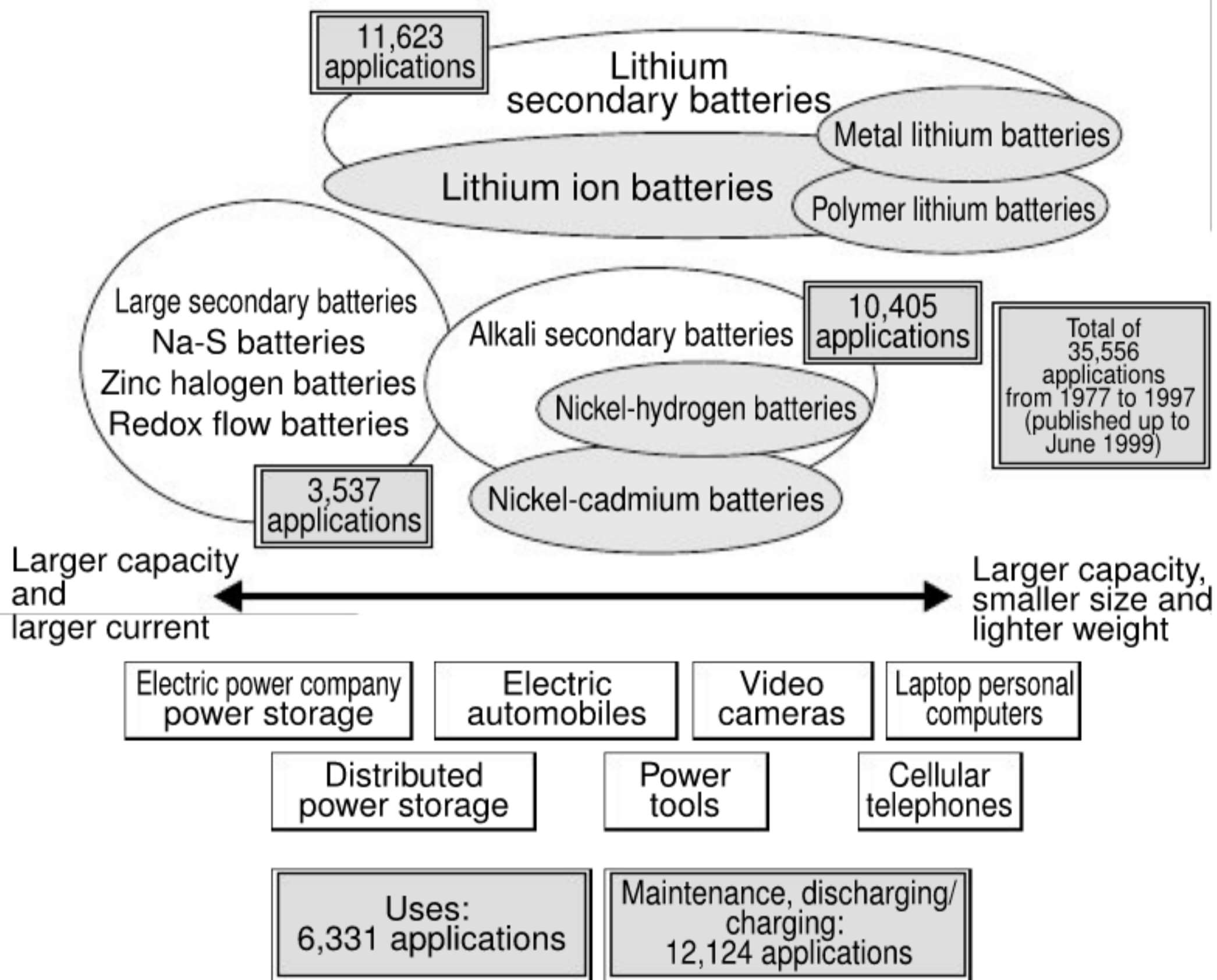

lithium ion batteries, metal lithium batteries and polymer lithium batteries) for 11,600 applications. Although lithium secondary batteries are used in compact and lightweight mobile electronic devices, they are also used in electric automobiles and distributed power storage, indicating that they are capable of accommodating a wide range of needs.

**Fig. 2 Tree map**

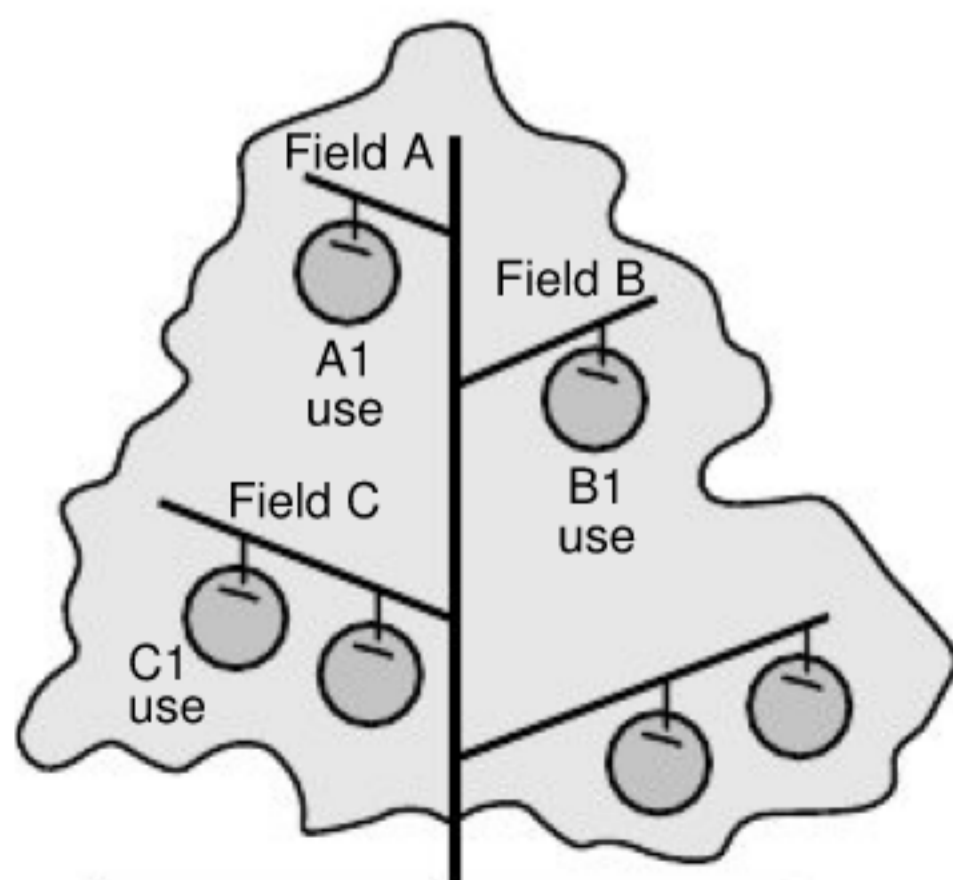

(2) Map Portraying Expanses of Applications of a Technology Field

A tree map (Fig. 2) is used to provide the spread of uses of a technology field. This map is produced by sorting out various patent classifications assigned to an extracted patents, and layering those classifications according to the uses and technology fields defined for them. Since these fields are those before actual commercialization and have been subjected to technical studies,

**Fig. 3 Uses of semiconductor lasers**

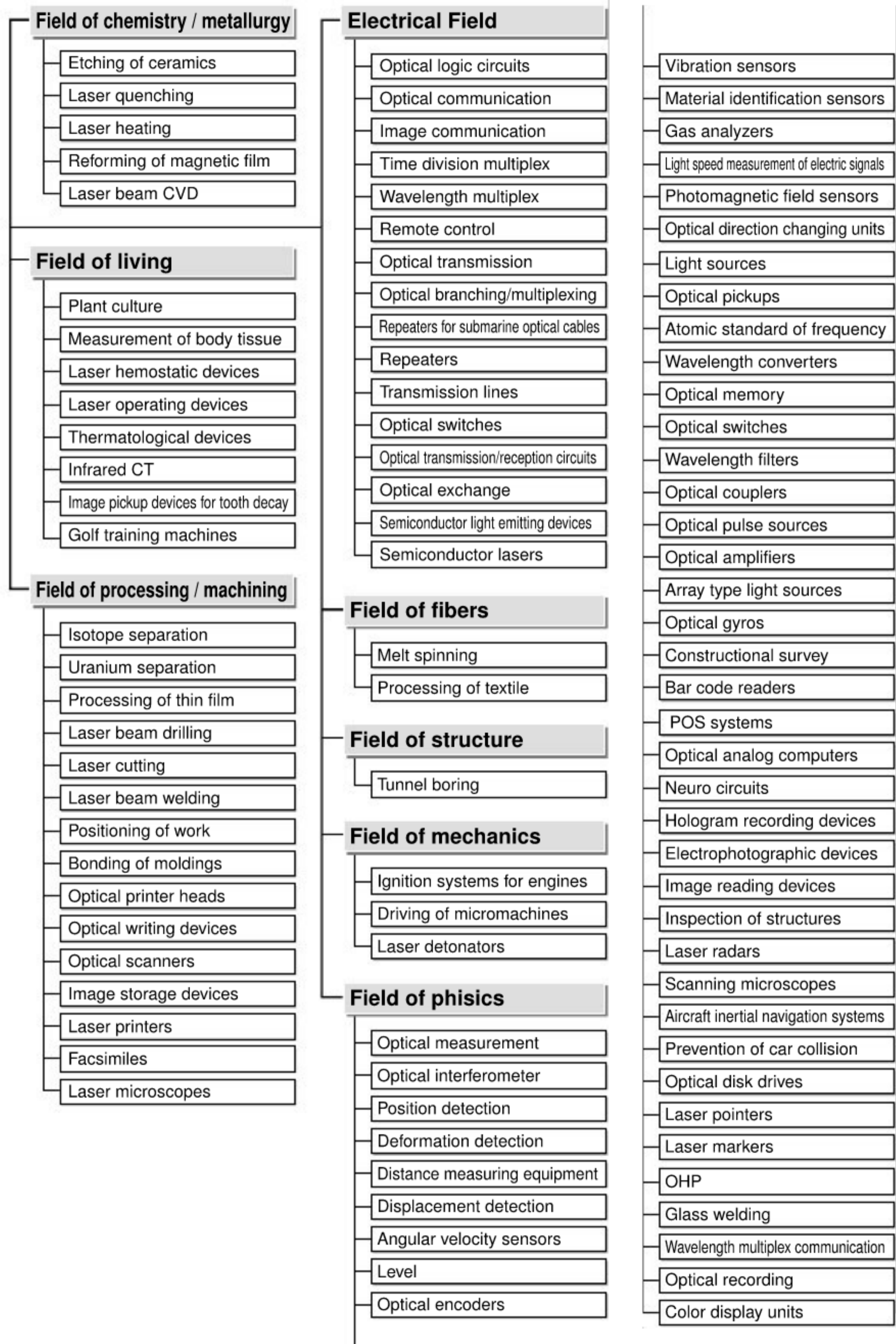

**Fig. 3 Uses of semiconductor lasers**

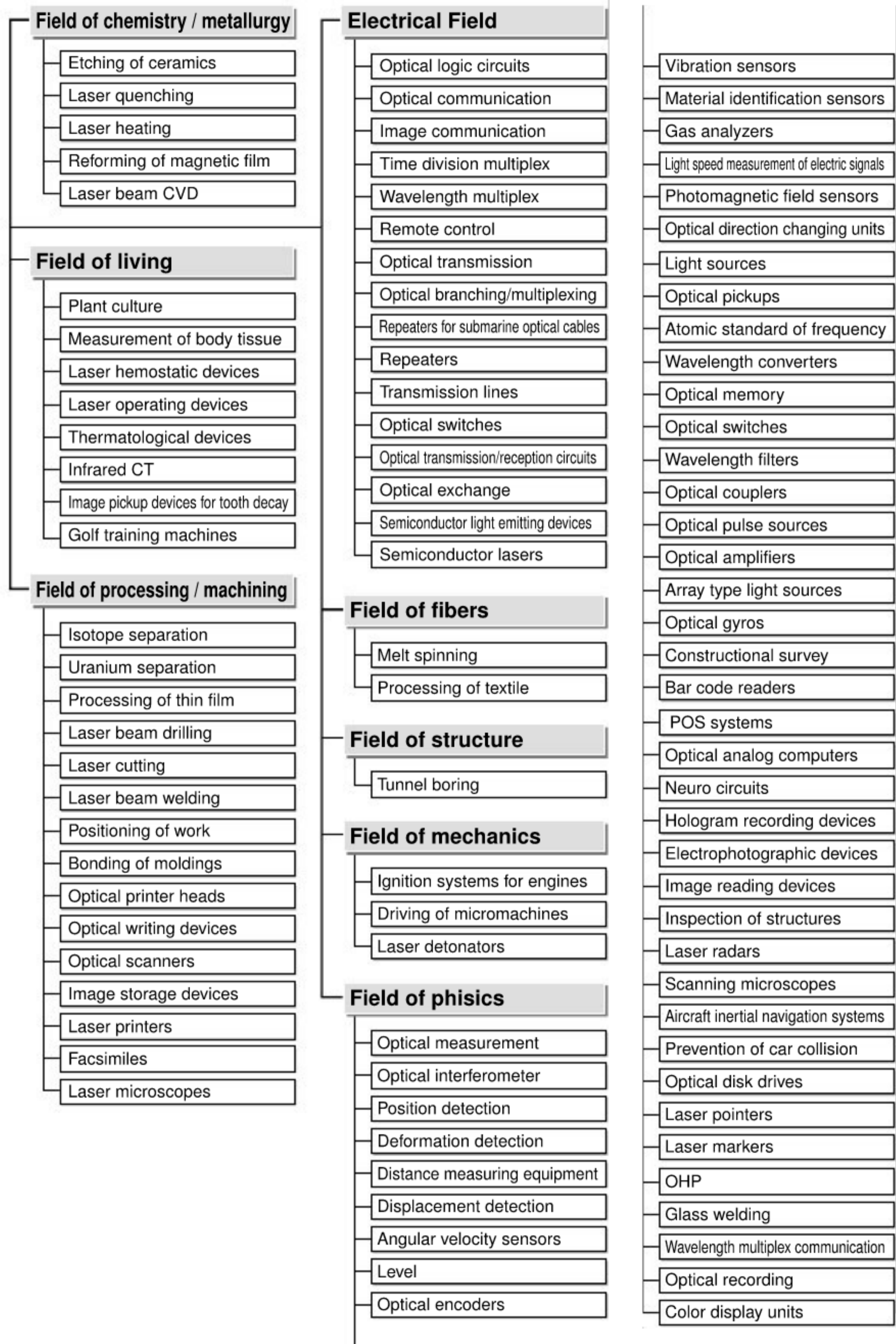

they can be viewed as uses having a high potential for realization.

### Case 2: Uses of semiconductor lasers (Fig. 3)

Fig. 3 summarizes the uses of semiconductor lasers in the form of branches in accordance with patent classifications.

Although examples of uses that have already reached the level of practical use include optical communications technology, optical information recording technology and laser printer technology, there are many prospect uses including measurement of the shapes of objects, distance and the rotating speed, using the properties of lasers.

Recently, due to the invention of blue lasers resulting in lasers being available for all three primary colors, it is likely that their uses will expand into fields such as display devices and lighting in the future.

Experiment results have also been reported indicating that short wavelength light promotes plant growth, thus making special light sources having a wavelength suitable for photosynthesis no longer a dream. It is also only a matter of time until high output lasers are developed for use in medical treatment.

Since body tissue is extremely dense and changes in a complex manner in response to temperature, the use of semiconductor lasers facilitating analog modulation can be seen to contain the hidden potential for developing sophisticated medical treatment.

### (3) Map Portraying Technology Fields Related to a Technology Field

Understanding the technical background of a technology field is one indicator for developing new technology. Patent maps used for this purpose utilize the relationships of

**Fig. 4 Relationship of patent classification**

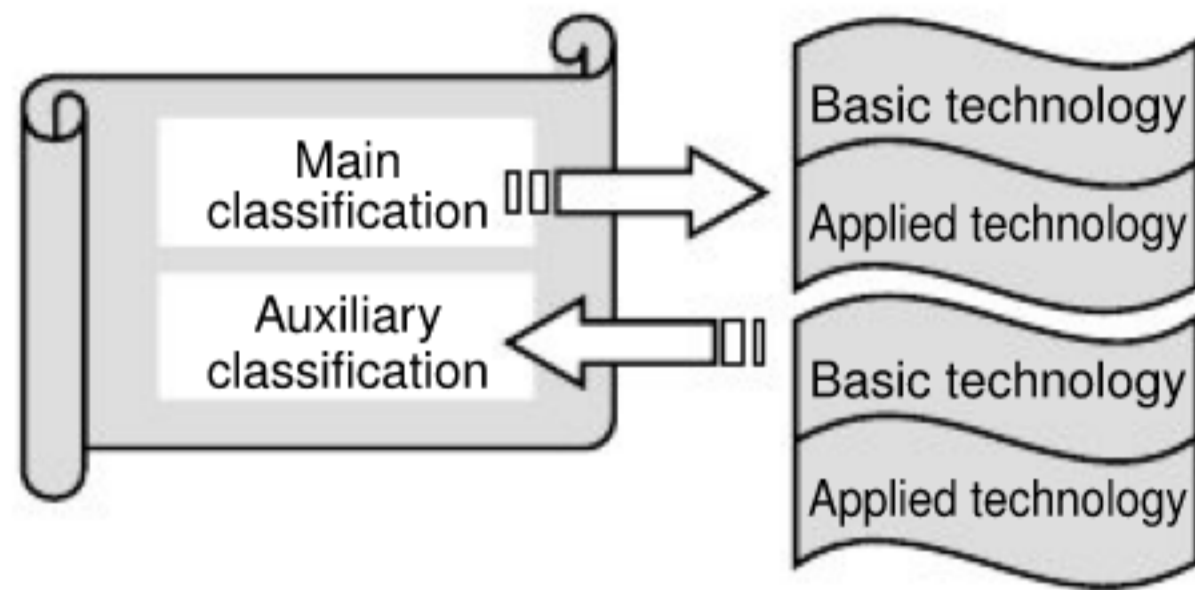

patent classification (classification of so-called main fields and auxiliary fields) which serves as a characteristic of patent information (Fig. 4). At the same time, the potential uses can also be forecasted from the relationships between these classification, and are extremely effective for the development of new technology or business expansion.

**Case 3: Influence of CAD technology (Fig. 5)**

Fig. 5 shows CAD technology divided into technology for which CAD technology is the main classification (first IPC) and technology for which CAD technology is the auxiliary classification (second IPC or after), along with those fields relating to each technology.

**Fig. 5 Influence of CAD technology**

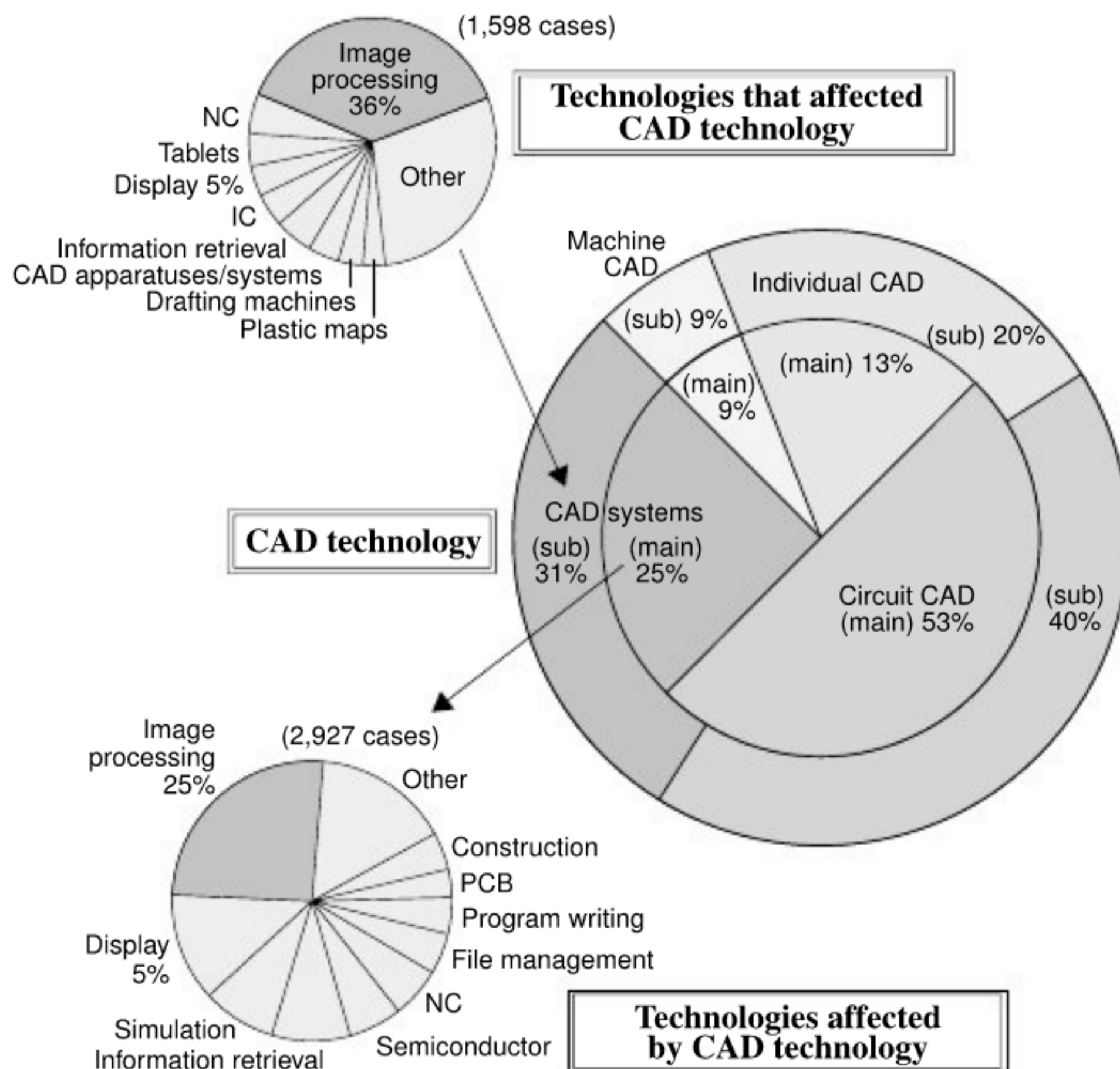
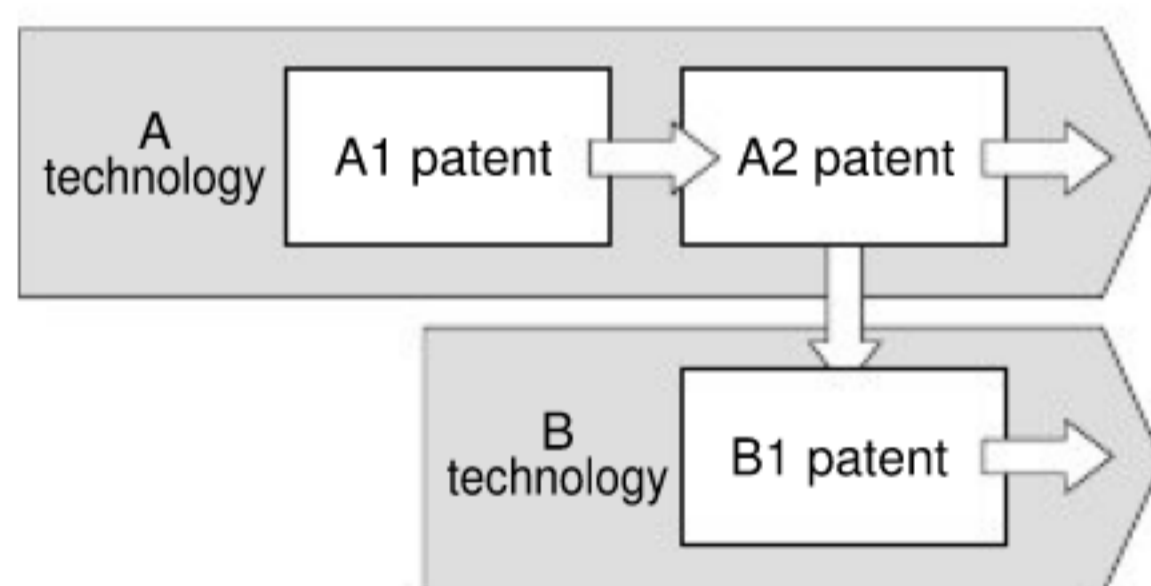

Image processing is both the technology that affected greatly CAD technology at 36% as well as the technology that was most affected by CAD technology 25%. Thus, image processing can be said to be the most important technology of CAD systems mutually correlated with CAD technology. Although displays only account for 5% of the technology that affected CAD technology, they account for 12% of the technologies that were affected by CAD technology. Viewing from display technology, this means that basic display technology was incorporated in the form of CAD technology, after which this technology developed in the form of CAD technology and was then reflected back in display technology.

#### (4) Map Portraying a Technological Progress

A time series map makes it possible to know the flow of technology from a basic patent along with the expanse of that technologies. This map is produced by extracting patents related to a technology field, layering them, and displaying them in a time series.

**Fig. 6 Time-series map**



In addition, by griping the source of these technologies as a result of ascertaining the process by which technologies developed, it can be used as information that provides a hint for creating new ideas.

As the map provides the relationship and the distribution of patent rights in a specific technology field, it allows the preparation of a specification for acquiring strong patent rights by comparing the time series of the distribution.

#### Case 4: Main technological progress of MPEG encoding method (Fig. 7)

Fig. 7 shows an overview of MPEG technology advancing towards the realization of high data compression rates.

Fig. 7 Progress of main technologies of MPEG encoding method

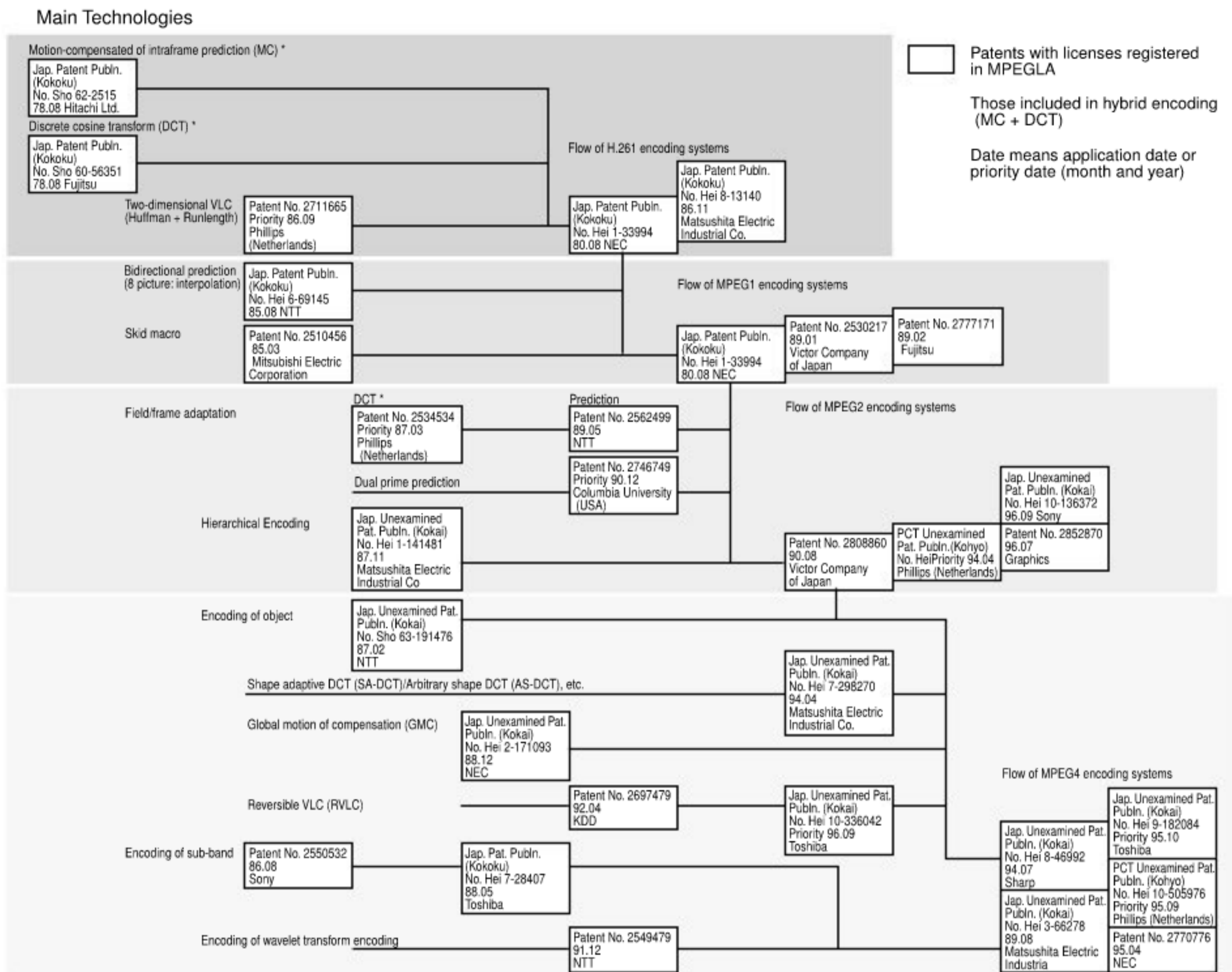

In the map, those patents contained in the solid boxes are licensed to MPEGLA (a private licensing company established through joint funding by member companies of MPEGIPR in July 1996) as noteworthy patents among MPEG2 encoding methods. This map makes it possible to observe the relationship between standardization and patents. Four encoding methods incorporate their own unique compression technology, and can be seen to adopt a form that is an extension of conventional systems.

The H.261 encoding method employed hybrid coding that combines MC and DCT. As a result, this system is able to significantly reduce time and spatial redundancies. This hybrid encoding can be seen to have enabled animated image compression technology to achieve the considerable strides it has made thus far.



## 2. To Find out Technological Changes

Technology is continuously changing due to the intense competition over the development of technology and the diversification of market needs. Being able to appropriately accommodate these changes is extremely important not only for venture companies and small and medium sized companies, but for proceedings with any kind of business.

There are patent maps which are produced by analyzing patent information based on the changes in the number of patent applications and the appearances of important patent.

### (1) Map Portraying Changes of Relations between Activity of a Technological Development and Participating Companies

**Fig. 8 Changes in number of applications**

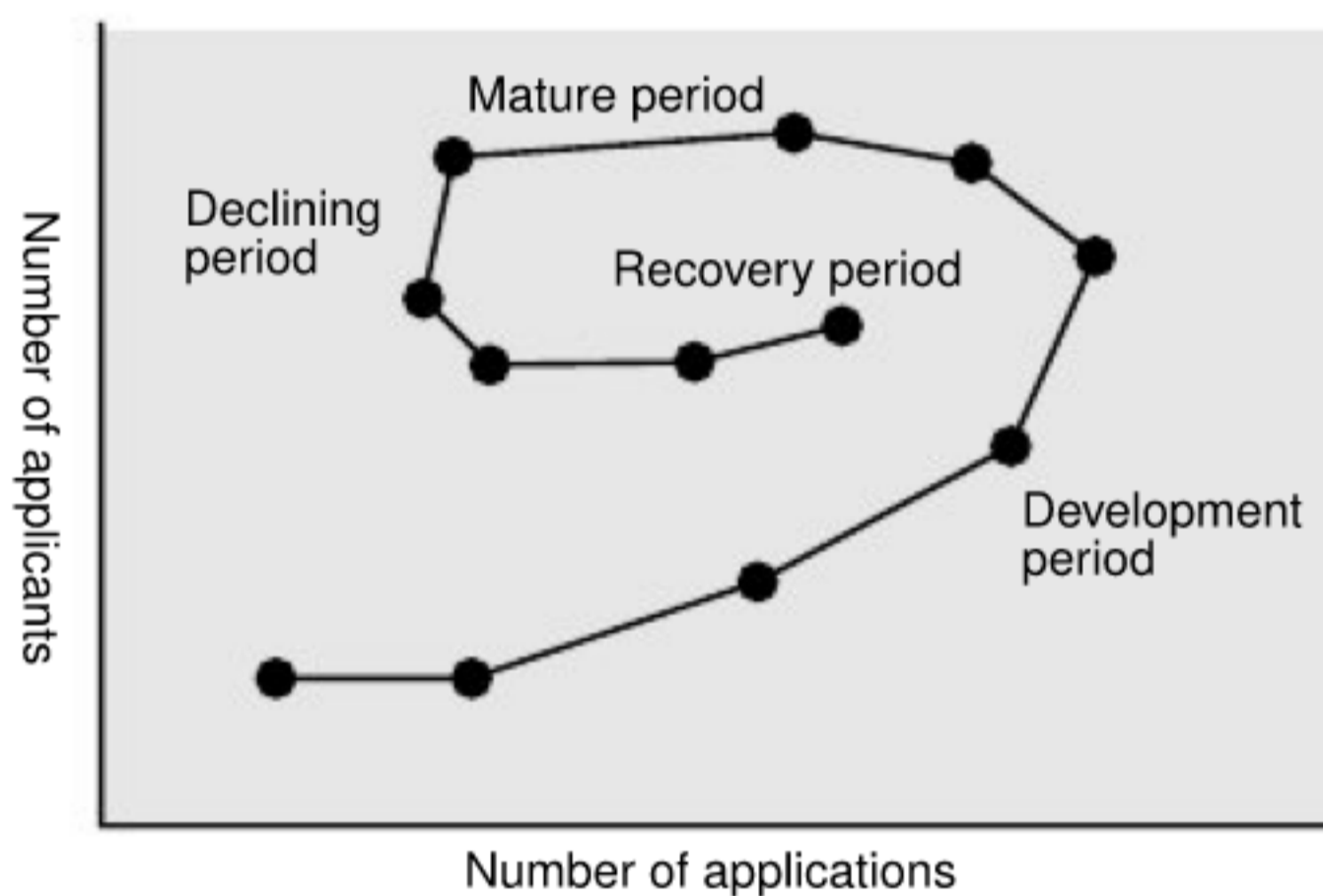

This map (Fig. 8) is a plot of the number of patent applications versus the number of applicants for each year.

Since the number of patent applications indicates technological development activities, while the number of applicants indicates the number of participating companies, observing this relationship makes it possible to grip the maturity of the technology field.

In addition, knowing the maturity of a technology field to which one's own company conducts makes it possible to judge the timing of development policies such as establishing technical tie-ups with other companies and focusing on certain development themes.

Case 5: Changes in the number of patent applications versus the number of applicants for optical disks (Fig. 9)

**Fig. 9 Changes in the number of patent applications versus the number of applicants for optical disks**

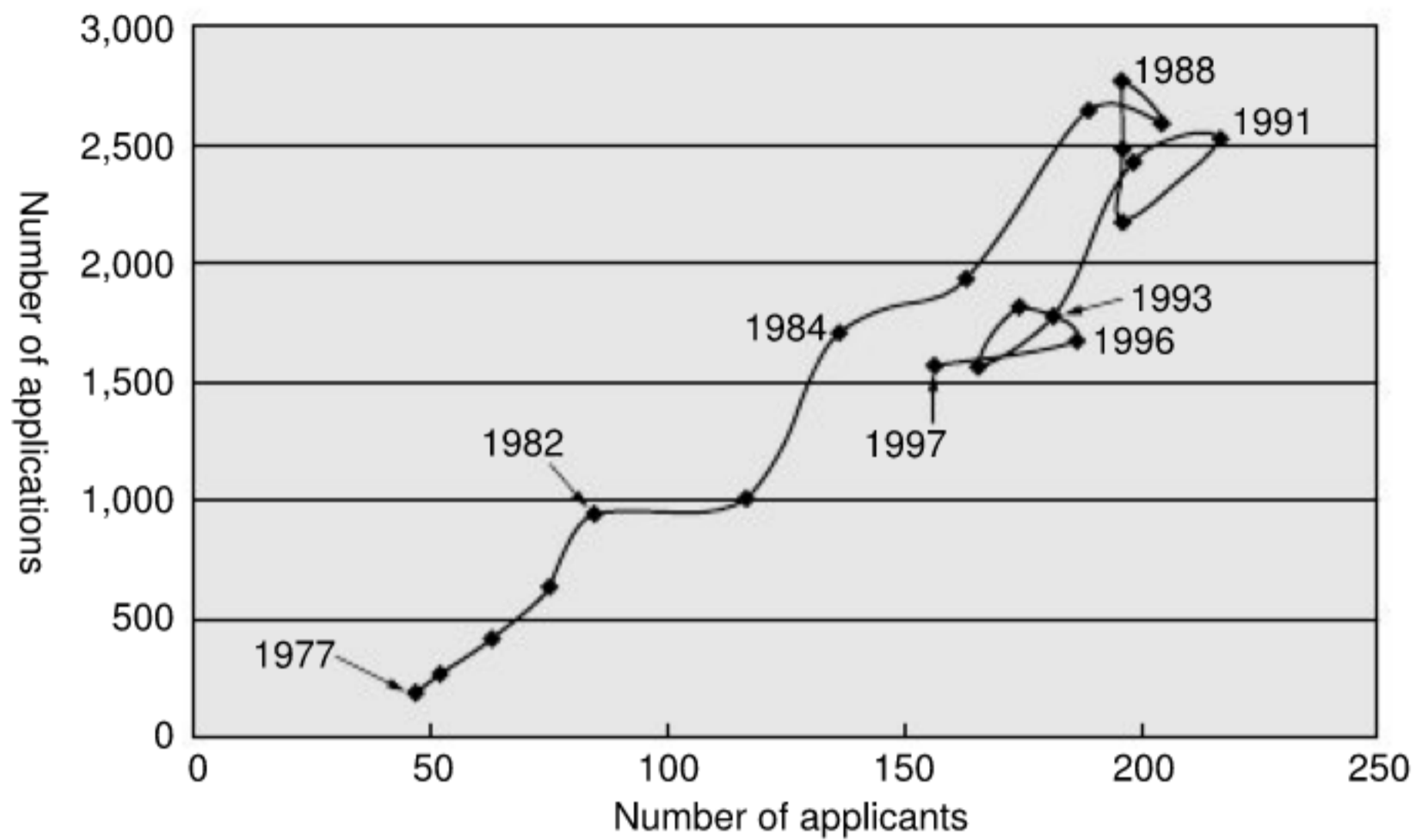

Fig. 9 shows the relationship between the number of applicants and number of patent applications for optical disks for each of the years from 1977 to 1997.

From this figure, it can be seen that the number of optical disk patent applications that were filed peaked in 1988, while the number of applicants peaked in 1991. In addition, the period from 1977 to 1988 can be seen to be a time when technological development expanded together with an increase in the number of new applicants entering the field, the period from 1988 to 1991 the first stabilization period, the period from 1991 to 1994, the technological development declining period, and the period from 1994 to 1997, the second stabilization period. On the basis of these findings, the industry can be said to have reached a turning point around 1988.

## (2) Map Portraying the Degree of Maturity of a Technology Field

This map (Fig. 10) is referred to as a portfolio map, and shows the life cycle of a technology field. Once a new technology field is born, it is represented in the form of stages consisting of growth, development, maturity and decline. This map makes it possible to show the current stage of the

**Fig. 10 Portfolio map**

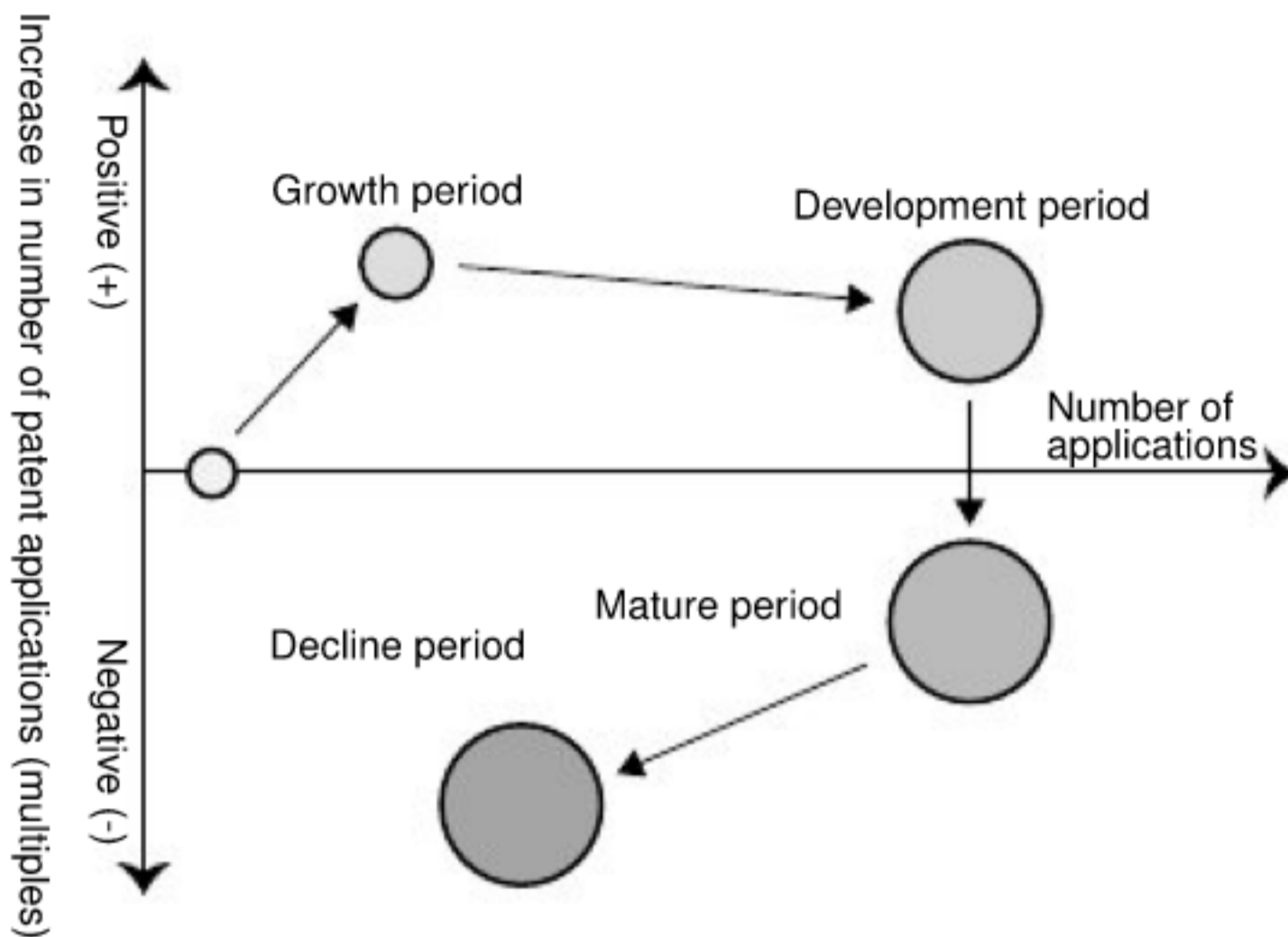

**Fig. 11 Changes in the number of patent applications for the technology field for converting agricultural waste into fertilizer**

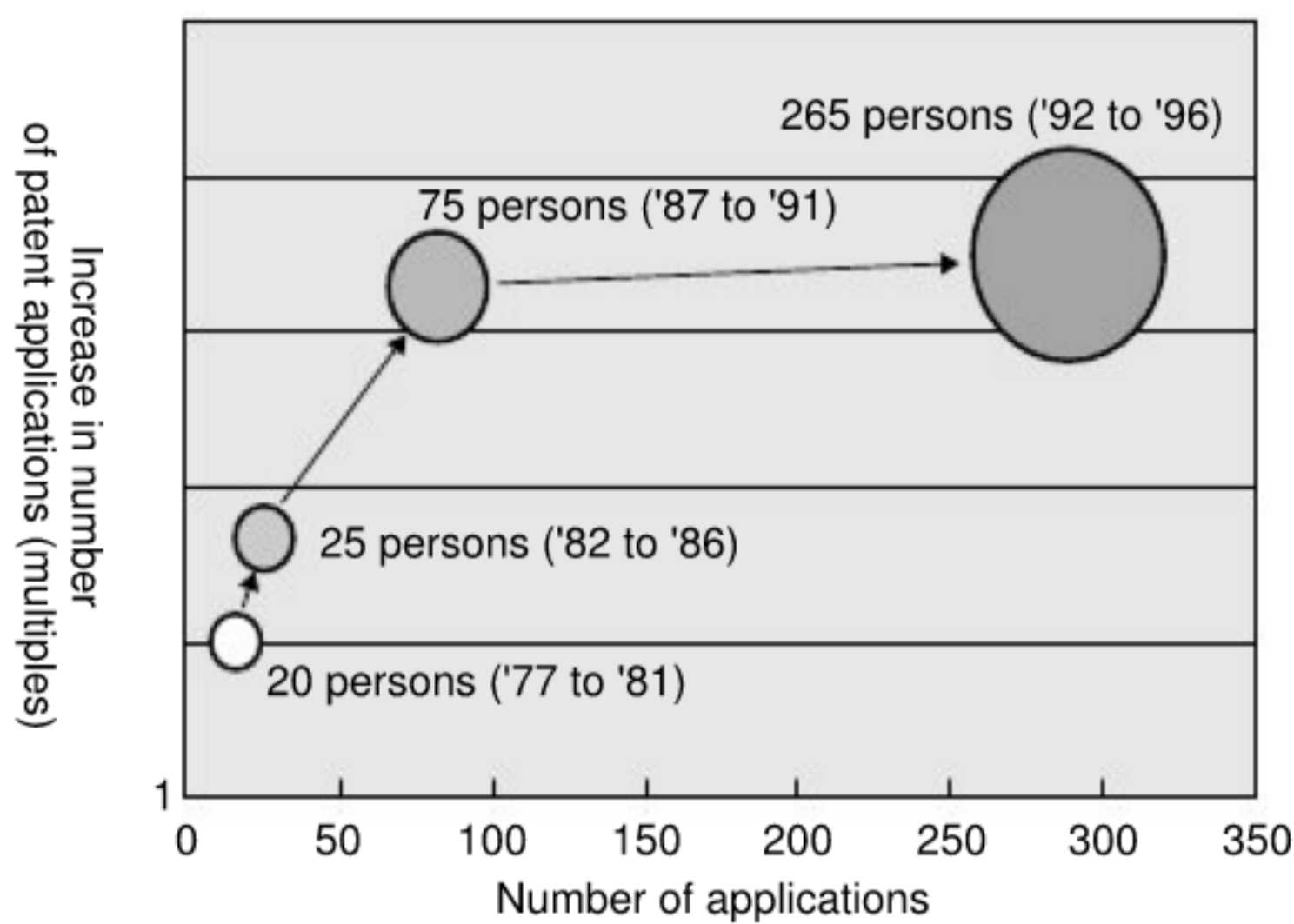

technology field.

This map makes it possible to observe the stage of technological development and is useful for judging whether a company should go into the business of the technology field or not.

Case 6: Changes in the number of patent applications for the technology field converting agricultural waste into fertilizer (Fig. 11)

Fig. 11 shows the ratio of the increase in the number of patent applications during a latter period relative to a former period plotted on the vertical axis and the total number of patent applications within a certain period plotted on the horizontal axis, with respect to the recycling of plant and animal waste into fertilizer.

From this figure, it can be said that the increases in the number of patent applications starting in or after 1987 grew to more than twice the number between each period, and that the number of applicants also increased rapidly. This indicates that the number of companies etc. newly entering the industry is increasing each year, and that the technology field is in the developmental stage.

**Fig. 12 Changes in the number of patent applications (two mountains analysis)**

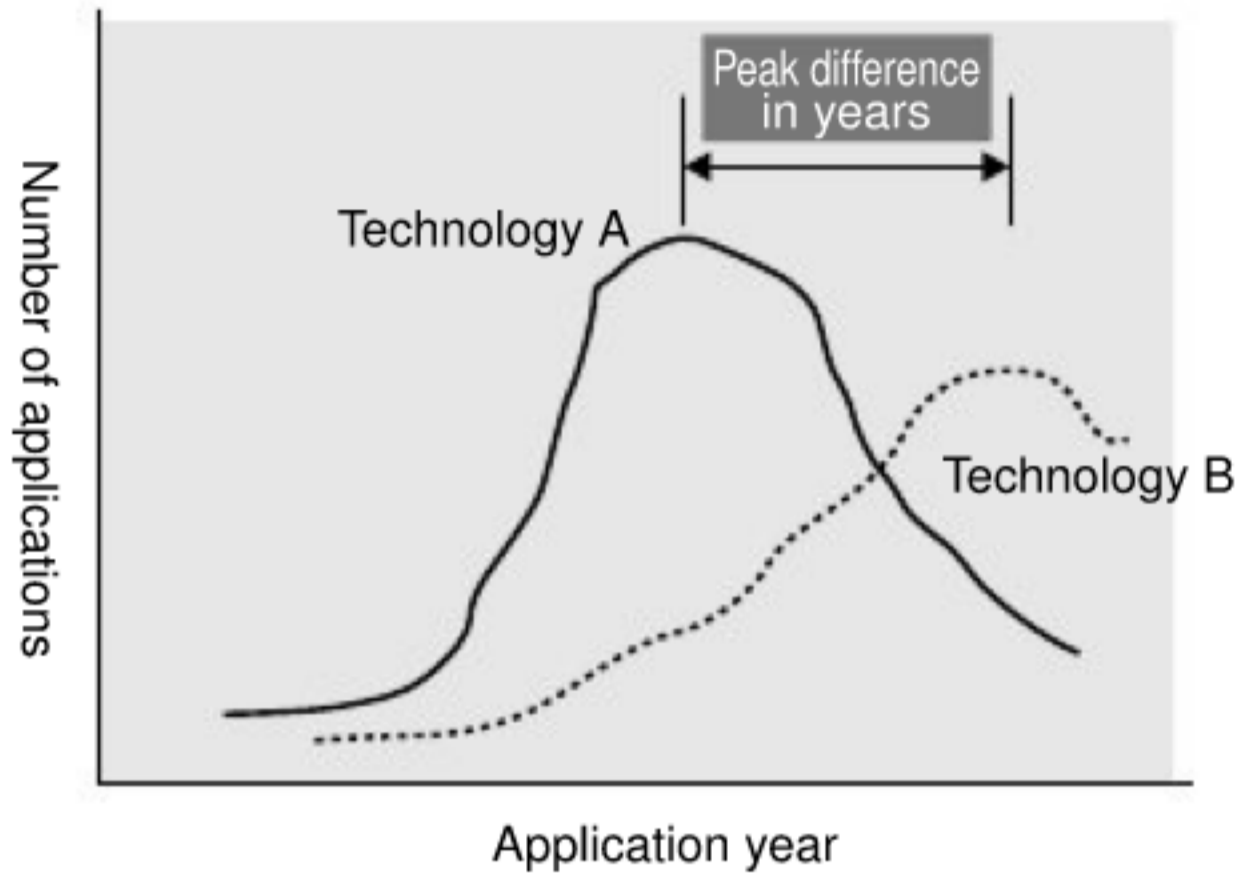

**Fig. 13 Changes in the number of patent applications for major technical fields of optical disks**

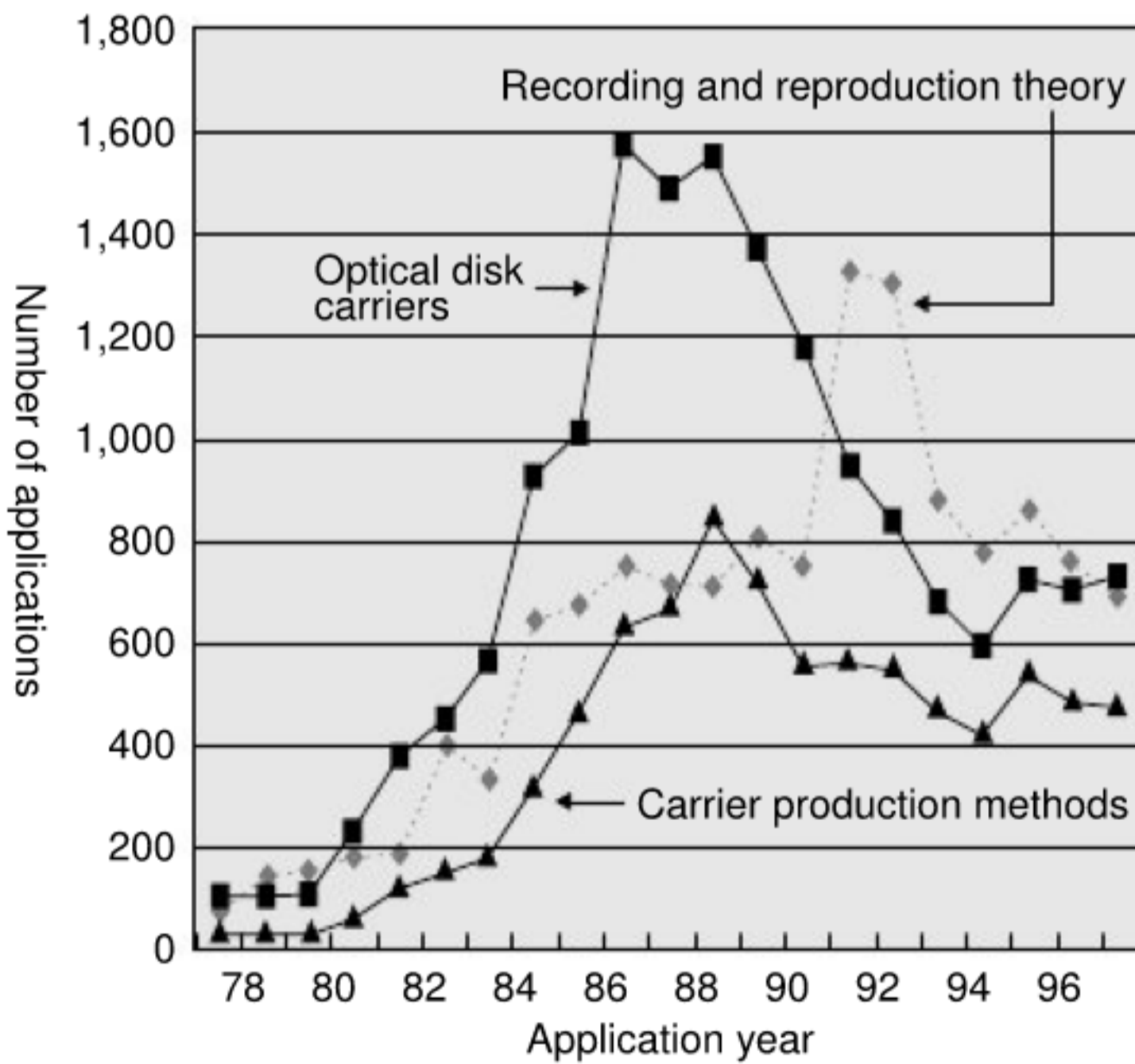

(3) Map Portraying Changes of Technical Contents

This map (Fig. 12) indicates the number of patent applications for each year for two technology fields. This patent map is referred to as two mountains analysis, and is used to show technical changes by comparing the shifts between corresponding peaks in the number of patent applications. In addition, it is also used to find a technology field for which market need is decreasing or being expected in the future.

Case 7: Changes in the number of patent applications for major technology fields of optical disks (Fig. 13)

Fig. 13 indicates the changes in the number of patent applications for the three major technologies that compose optical disks, namely "recording and reproduction theory", "optical disk carriers" and "carrier production methods".

It can be seen from this figure that, after appearing to have reached a technically mature stage around 1988, development activity again accelerated in the area of the "record-

ing and reproduction theory" around 1991, resulting in the technology entering a development stage for next-generation products. On the basis of these findings, the development of optical disk technology is seemed to progress in this order.

**Fig. 14 Matrix analysis**

	Element (purpose, etc.)			
Element (function, etc.)		↓		
		●		

(4) Map Portraying Trends of Problems in a Technological Development

This map (Fig. 14) is referred to as a matrix analysis.

Portraying the correlation between technical elements (such as purpose and function) obtained from patent information in the form of a matrix makes it possible to show

important problems affecting the development of a technology field. Moreover, with the addition of a time axis, trends in problems affecting technological development can also be observed. As a result, since technical trends can be caught, the selection of development themes and studies of priority can be conducted effectively when planning and proposing them.

Case 8: Map relating to dioxin decomposition of fluid bed incinerators (Fig. 15)

Fig. 15 shows a trend in which patent applications were concentrated during the period from 1990 to 1995 in response to the announcement of guidelines by the Ministry of Health and Welfare (1990).

Although patent applications consist primarily of those in fields related to fluid bed combustion characteristics and secondary combustion mixing and temperature control that have a direct effect on dioxin decomposition, starting in the 1980's and up to the present, it can be seen that patent applications have continuously been filed relating to the accommodation to fluctuations of refuse type and volume.

**Fig. 15 Map relating to dioxin decomposition of fluid bed incinerators**

Purpose	Dioxin decomposition only					Cost reduction					Improved maintenance					Accommodation to fluctuations of refuse type and volume					Heat recovery and others					
	84-86	87-89	90-92	93-95	96-98	84-86	87-89	90-92	93-95	96-98	84-86	87-89	90-92	93-95	96-98	84-86	87-89	90-92	93-95	96-98	84-86	87-89	90-92	93-95	96-98	
Fluid bed combustion characteristics		●	●	●						●					●					●					●	●
Secondary combustion temperature control		●	●	●	●			●										●	●						●	
Secondary combustion mixing control		●	●	●				●					●						●							
Secondary combustion retention time		●	●	●																						

● represents one patent.

**Fig. 16 Analysis of changes in numbers of patent applications by industry field**

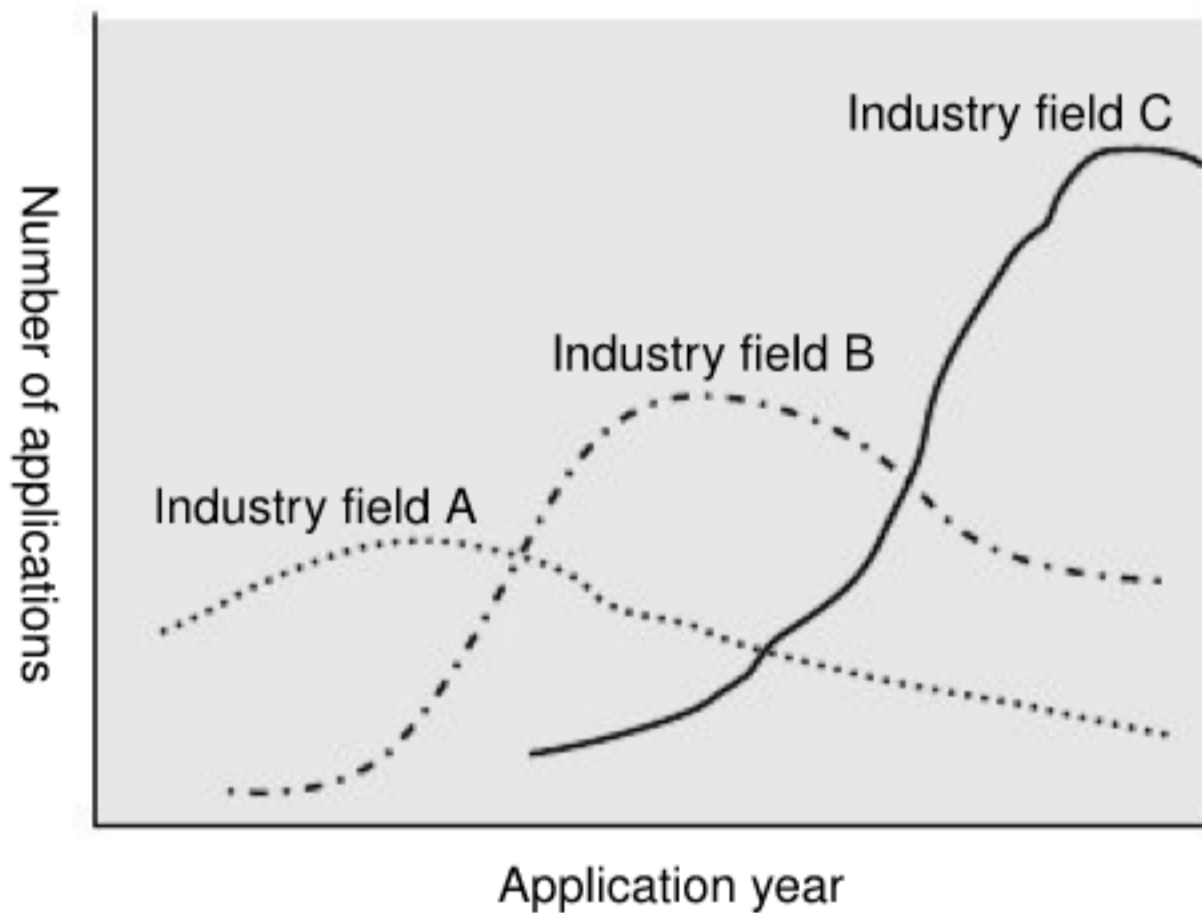

**(5) Map Portraying Changes of Influential Industrial Field in Technological Development**

This map (Fig. 16) shows changes in a major industry field active in the area of a technology field.

A change in the major industry field means that the development of the major technology field entered a new stage. The change in industry field responsible for the technology

field is useful in finding the potential for new entry into that industry field.

**Case 9: Number of patent applications by industry field relating to the shape of rotary blades of tenoning machines (Fig. 17)**

Fig. 17 shows the changes in the respective numbers of patent applications by dividing those manufacturers ranked from first to tenth in the number of patent applications throughout the entire period into industry fields consisting of

**Fig. 15 Map relating to dioxin decomposition of fluid bed incinerators**

Purpose	Dioxin decomposition only					Cost reduction					Improved maintenance					Accommodation to fluctuations of refuse type and volume					Heat recovery and others					
	84-86	87-89	90-92	93-95	96-98	84-86	87-89	90-92	93-95	96-98	84-86	87-89	90-92	93-95	96-98	84-86	87-89	90-92	93-95	96-98	84-86	87-89	90-92	93-95	96-98	
Fluid bed combustion characteristics		●	●	●						●					●										●	●
Secondary combustion temperature control		●	●	●	●			●										●	●						●	
Secondary combustion mixing control		●	●	●				●					●													
Secondary combustion retention time		●	●	●																						

● represents one patent.

**Fig. 16 Analysis of changes in numbers of patent applications by industry field**

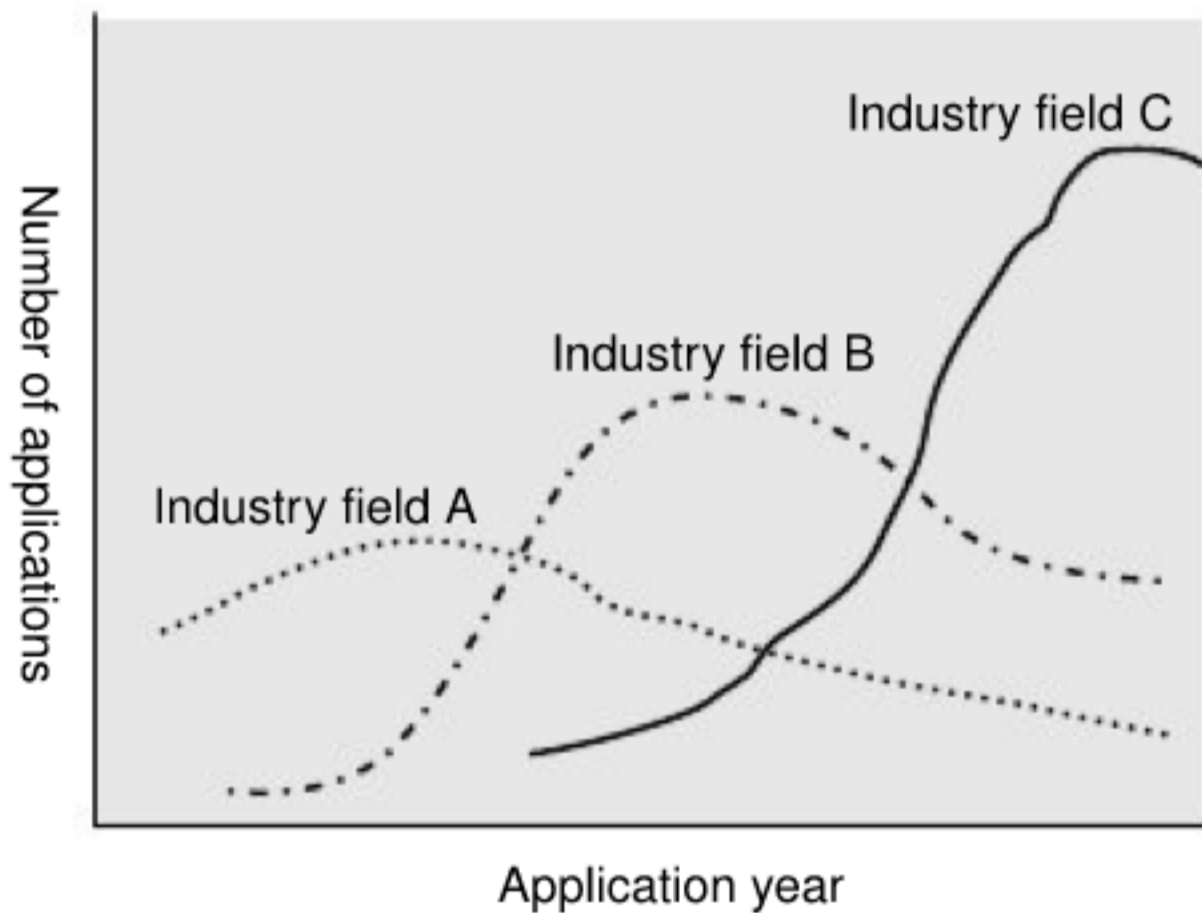

**(5) Map Portraying Changes of Influential Industrial Field in Technological Development**

This map (Fig. 16) shows changes in a major industry field active in the area of a technology field.

A change in the major industry field means that the development of the major technology field entered a new stage. The change in industry field responsible for the technology

field is useful in finding the potential for new entry into that industry field.

**Case 9: Number of patent applications by industry field relating to the shape of rotary blades of tenoning machines (Fig. 17)**

Fig. 17 shows the changes in the respective numbers of patent applications by dividing those manufacturers ranked from first to tenth in the number of patent applications throughout the entire period into industry fields consisting of

**Fig. 17** Number of patent applications by industry field relating to the shape of rotary blades of tenoning machines

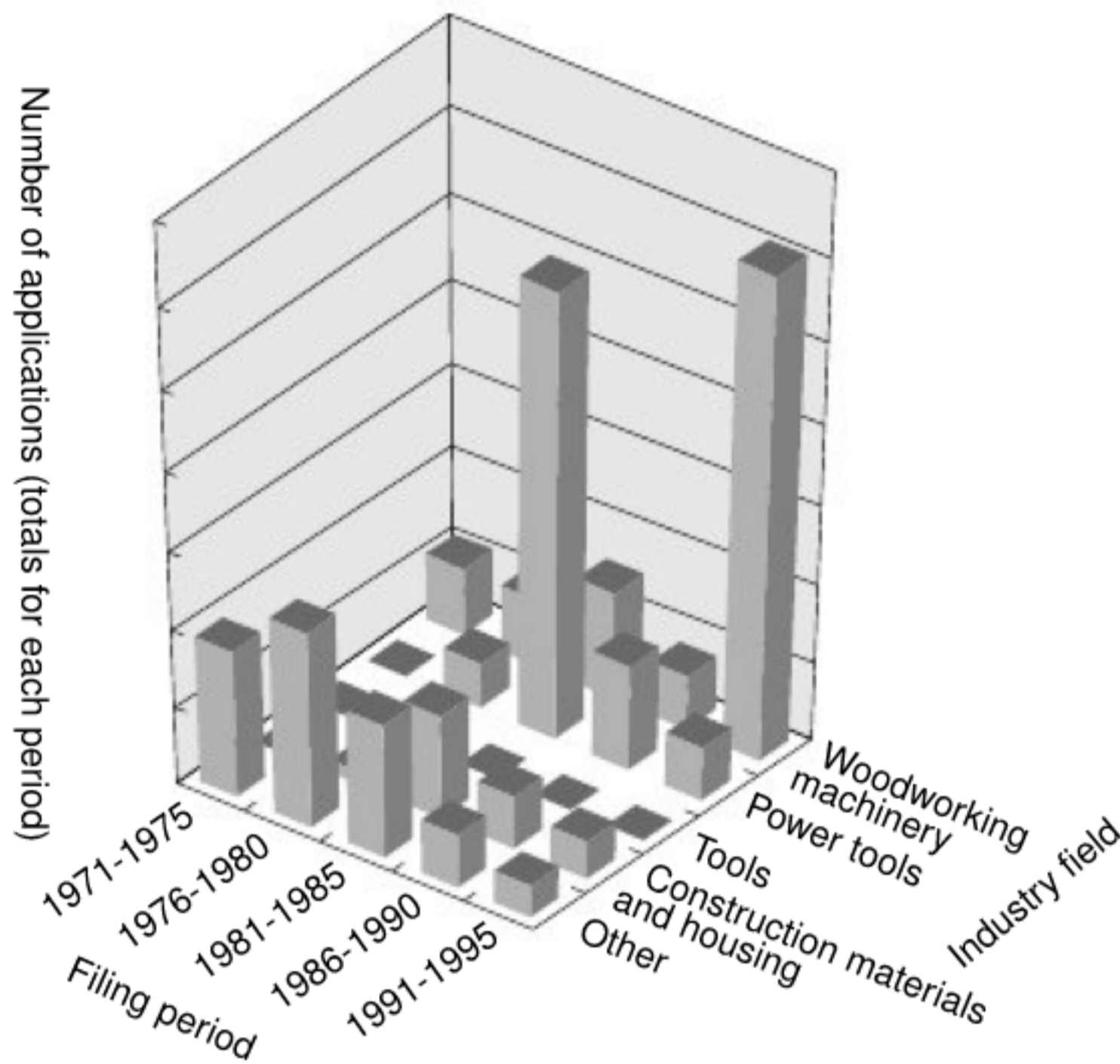

woodworking machinery, power tools, tools, construction materials, housing and others with respect to rotary blade tenoning machines.

In this study, a clear change in leading industry field from the power tool to the woodworking machinery can be seen. On the basis of this information, technical factors permitting new entry into the field can be further clarified by analyzing main manufacturers and core technologies of the woodworking machinery.

(6) Map Portraying a Technological Development

This map (Fig. 18) shows elementary technologies mutually connected by a core technology in the order of patents filed for important technologies relating to new methods, new structures etc.

**Fig. 18:** Map of technology development

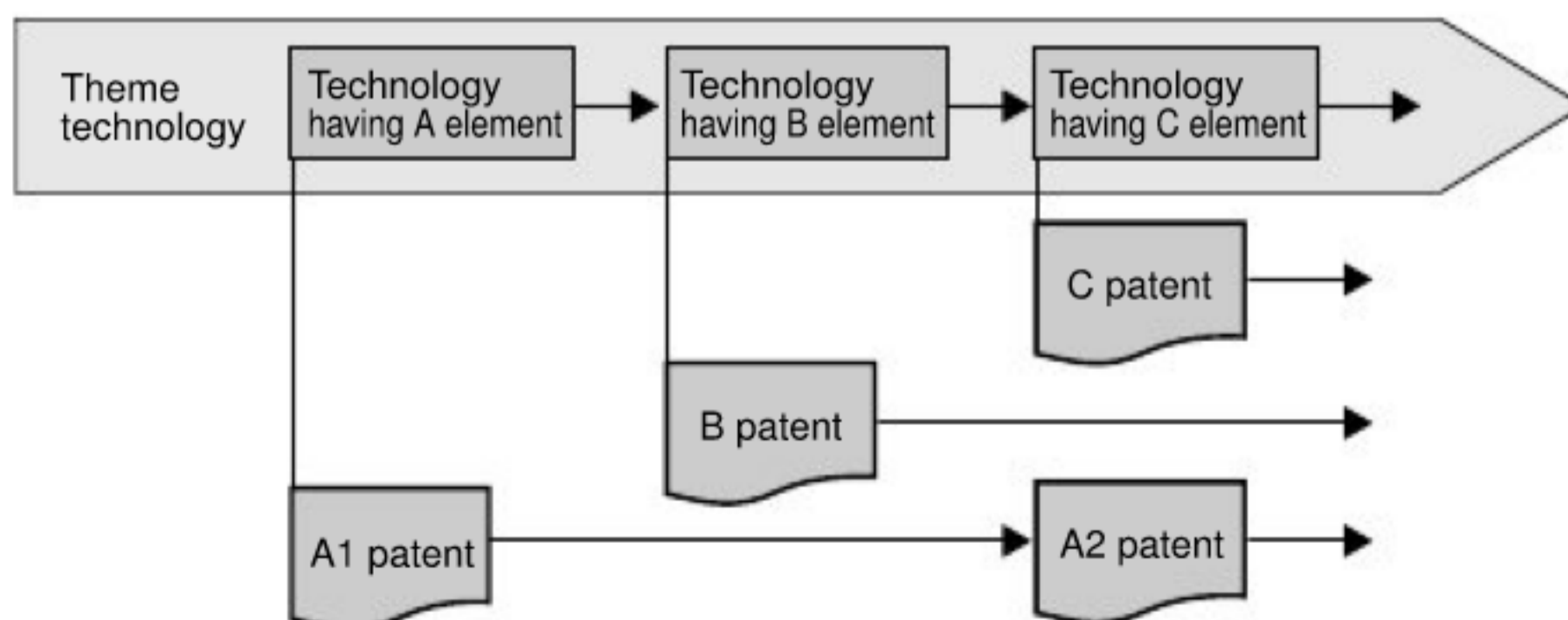

This patent map makes it possible to view the technical structure and the expanse of technological development of the technology field, the existence of specific patents that must be paid attention. In addition, since



it also provides a complete image of the technology field, it is capable of providing a hint for forecasting the direction of technological development and planning of new products.

### Case 10: Basic patents for semiconductor lasers (Fig. 19)

Fig. 19 shows basic patents of semiconductor lasers in chronological order. It can be seen that the world's first semiconductor laser was invented by a Japanese in 1957. Later, new devices were invented, led primarily by the US, and various inventions were added to enable laser excitation at low temperatures and eventually at room temperature. At the practical application stage, it can be seen that Japan has overcome technological problems including prevention of deterioration, unification of vertical mode, and reduction of threshold value for excitation.

Since the direction of technological development can be expanded by following the course of a core technology like showing the above map, the actual development plan can be provided.

### 3. To Seek Business Opportunities

In order to enter into a new business, it is necessary to accurately grip the market needs and technological needs, as well as focus on those fields in which patents have not been applied thus far. In addition, it is also necessary to evaluate the value of patents and efficiently to introduce patents targeted at an important technology field.

Patent map can show matrix analyzing multi-faceted seeds and needs of a technology field.

#### (1) Map Portraying the Status Quo of Applications with Multiple Perspective of a Technology Field

This map shows multiple viewpoints, including technologies, uses and applicants, into a matrix to analyze the strength of development activities (and patent rights) of a

Fig. 19 Basic patents of semiconductor lasers

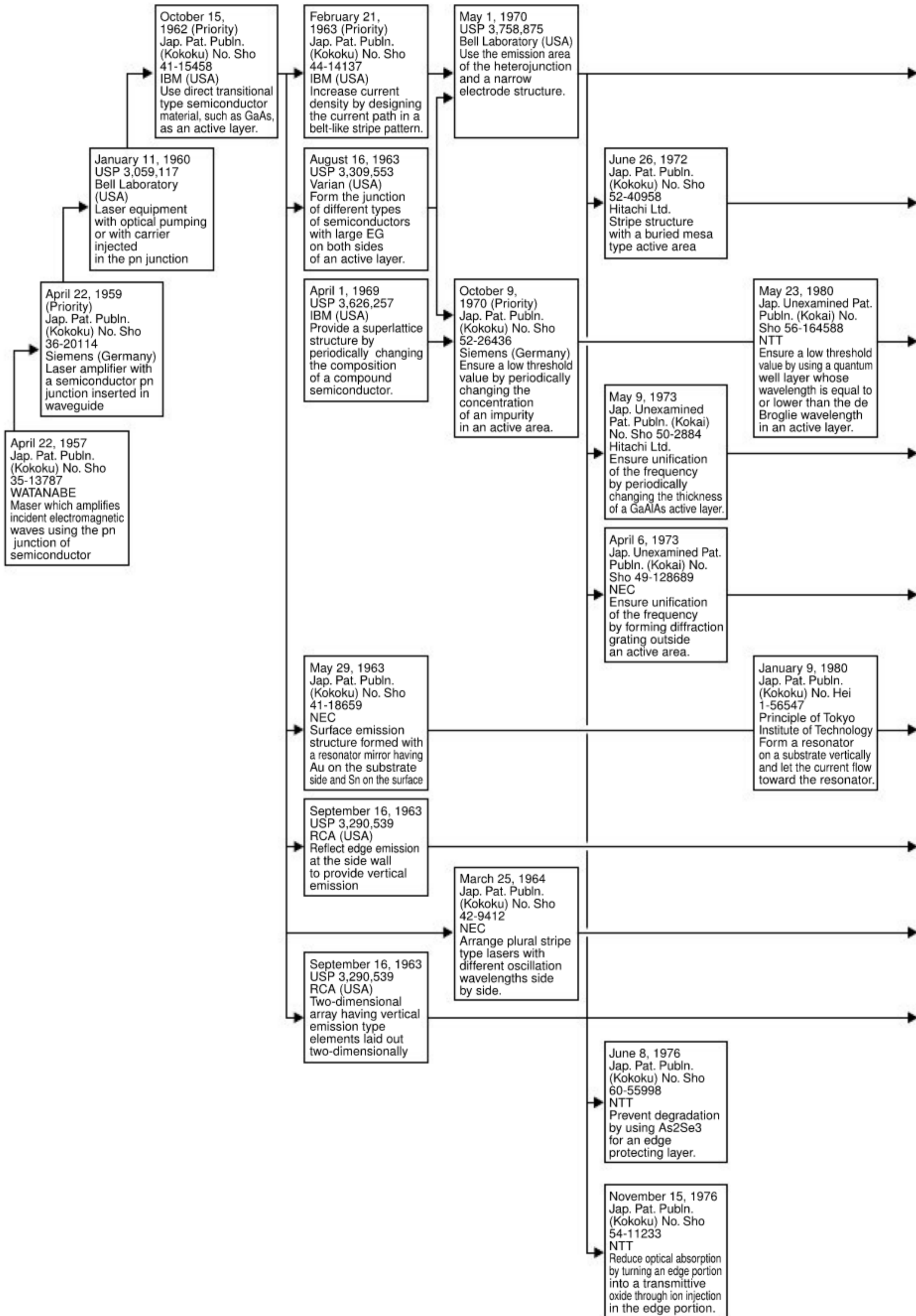

**Fig. 20: Three-dimensional bar graph**

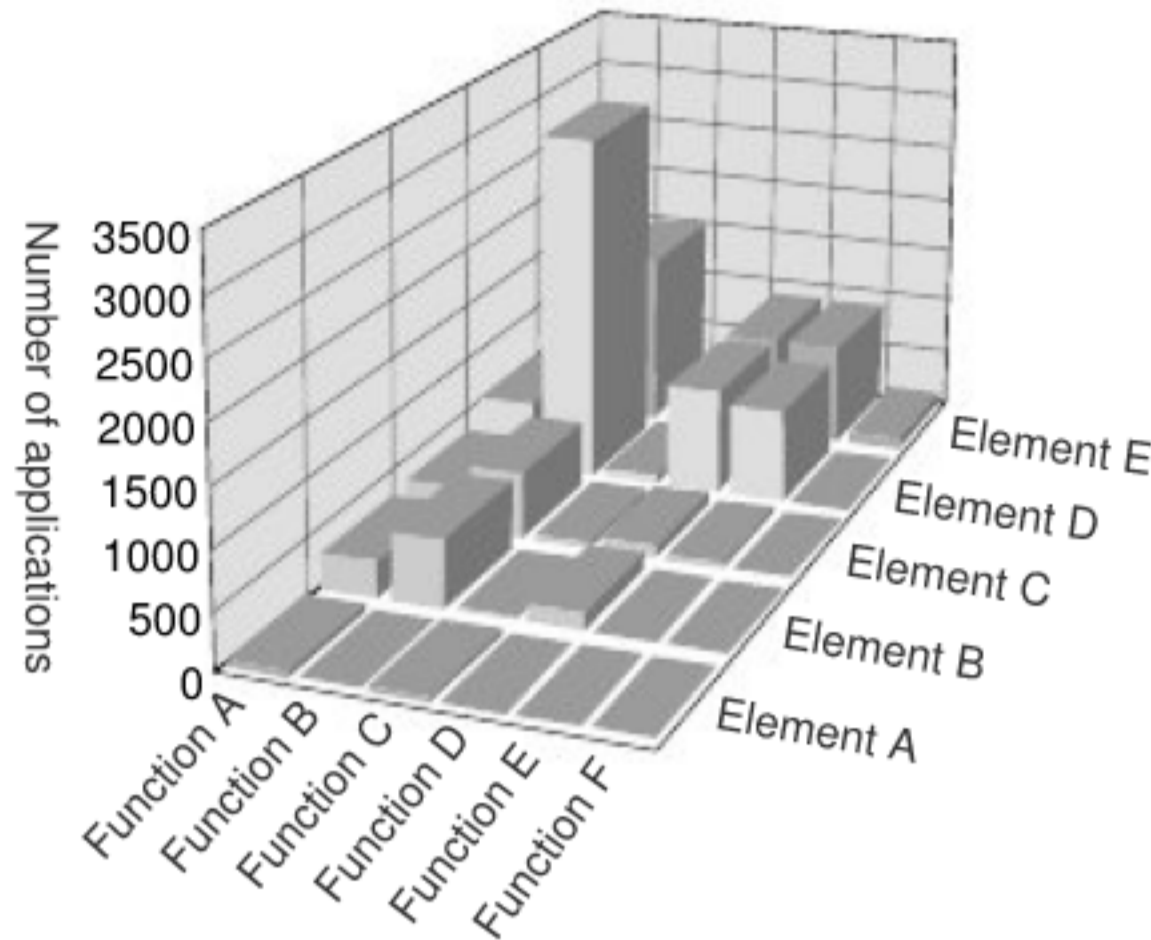

technology field. Viewing these strengths makes it possible to observe the characteristics of the technical field and decide the direction of product development. In addition, stable fields in which technology has already been established or prospect fields in which there are few patents can also be found.

Typical examples of this map include three-dimensional bar graphs like those shown in Fig. 20, and contour graphs and matrix charts like those shown in Fig. 21.

**Fig. 21: Matrix chart**

: Other companies    : Own company

	Reliability	Economic feasibility	Sense of quality	Safety	Total
Dimming					
Heat reflection					
Shading					
Total					

Total column : No. of rights held by other companies (upper figure) and those held by own company (lower figure)

contour graphs and matrix charts like those shown in Fig. 21.

Case 11: Number of patent applications by uses and by IC cards (Fig. 22)

**Fig. 22 Number of patent applications by uses and by IC cards**

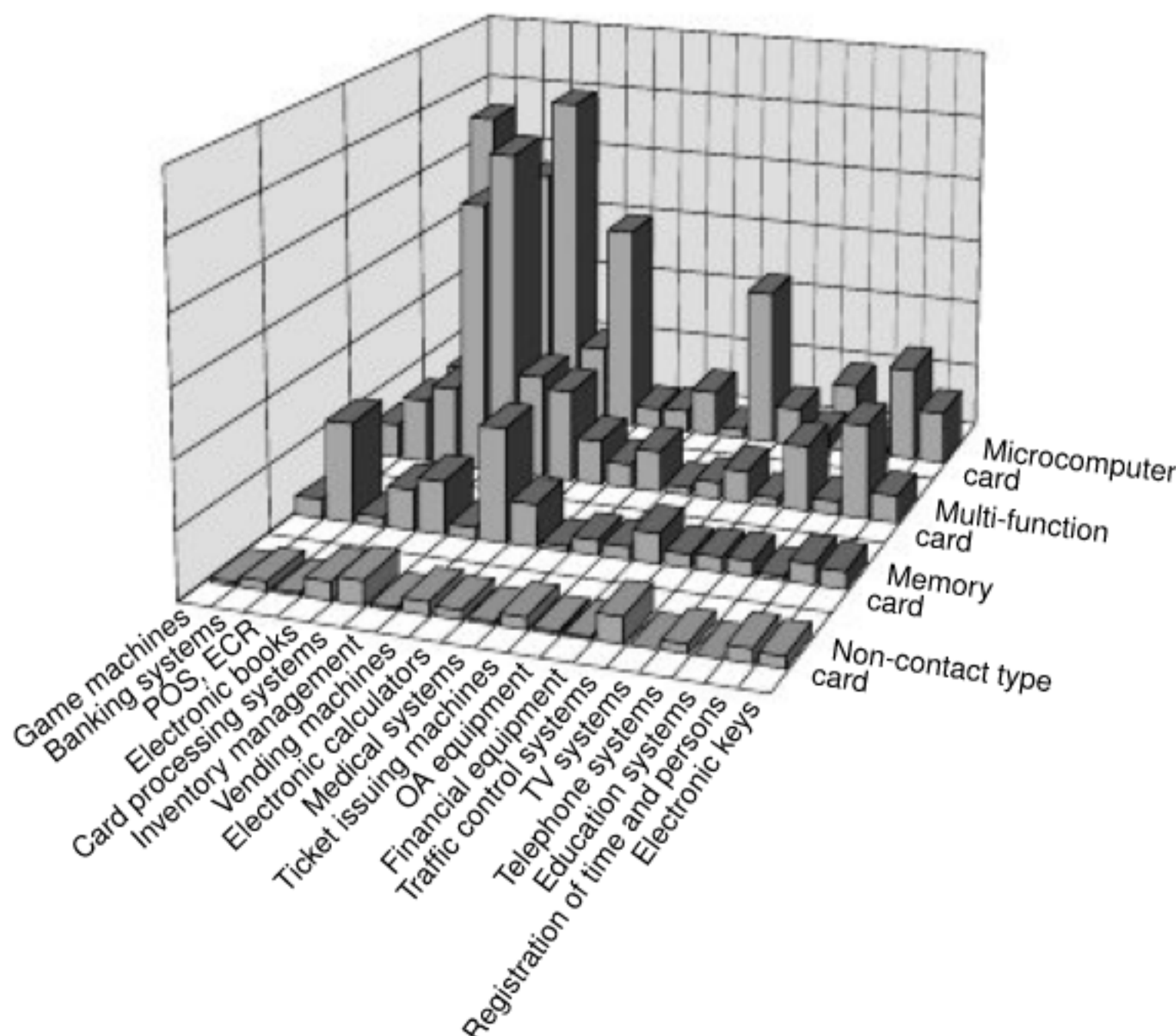

Fig. 22 shows what types of IC cards are used in the form of a three-dimensional matrix bar graph. It can be understood from this graph that memory cards are frequently used in automatic vending machines, banking and card processing systems, microcomputer cards are used in banking

systems, automatic vending machines and cash dispensers, multi-functional cards are used in electronic books, inventory control, so-called time cards for time and personnel registration systems, and non-contact cards are used in traffic control systems and card processing systems to take advantage of their non-contact characteristics.

## (2) Maps Portraying Problems in a Technological Development

This map shows important problems that inventions are attempting to solve, its objectives, means of attaining the objectives and the effects of these inventions by scanning typical patents in a specific technology field, by summarizing those results in the form of a list.

Since this map indicates concrete problems to be solved along with the various corresponding means for solving those problems, it can serve as a shortcut in finding solutions to similar technical problems encountered.

In addition, since the correlation between object/effect and methods/means is shown in a time series, it is possible to judge the direction of technological development.

### Case 12: Problems and solutions of typical patents for the processing of agricultural waste into fertilizer (Fig. 23)

Fig. 23 shows a objectives/methods matrix for the processing of animal and plant waste into fertilizer.

It can be understood from this figure that the promotion of fermentation to produce fertilization in a short period of time by using microorganisms, aerating during fermentation or employing various types of control has been the most important technological issue in recent years.

These are all considered to be uses of microbial culturing technology and know-how due to the growing activity in

**Fig. 23 Problems and solutions of typical patents for the processing of agricultural waste into fertilizer**

Objective/effect Method/means	Promotion of fermentation			Improvement of fertilizer quality			Standardization of fertilizer quality			Cost reduction		
	'80	'85	'90	'80	'85	'90	'80	'85	'90	'80	'85	'90
Pretreatment												
Additives												
Microorganisms												
Aeration												
Control												

◻ : Published or registered patents    ◻ : Unexamined patents (pending)

the field of bio science.

Although fermentation processing is normally carried out by microorganisms in the case of converting agricultural waste into fertilizer, due to the high fiber content (cellulose) which is different from livestock waste and marine waste, a

longer period of time and a larger area are required to obtain fertilizer. Consequently, accelerating fermentation to convert to fertilizer in a shorter period of time by pretreating the waste, using specific species of microorganisms, performing aeration during fermentation or applying various types of control is becoming main technological target. Among these methods, although pretreatment has been carried out since long ago, it can be seen that efforts have concentrated on microorganisms, aeration and control starting in the latter half of the 1980s.

Moreover, it can also be seen that improving the quality of fertilizer has recently become an important target.

### Case 13: Problems and solutions of the development of optical disk recording technology (Fig. 24)

Fig. 24 shows the multiplex recording system and multi-value recording system with respect to the big target of high-density recording and illustrates the basic techniques and related techniques that support the basic techniques, such as pit shapes and cross-talking.

Fig. 24 Problems and solutions of the development of optical disk recording technology

	Problem of invention		Solutions	Patents
	Problem	Specific problem		
Recording	High-density recording	To improve high-density recording by a multiplex recording system	Plural wavelengths are used for storing address information by using an optical disk medium whose optical property changes according to the wavelength of a laser beam.	Jap. Pat. Publ. (Kokoku) No. Hei 7-82645
			In wavelength-multiplex recording, signals are prerecorded on a part of an optical disk medium with lights of individual wavelengths to be used, and at the time of signal recording or reproducing, the signals are read from the part and the wavelength of a light source is tuned to the individual wavelengths.	Patent No. 2505790
			A recording medium having plural recording films and a reflection film is used, and one of the recording films is selected by utilizing the phenomenon such that as a laser beam is supplied from the recording film side, it interferes with reflected light from the reflection film to thereby produce a light intensity distribution, and utilizing the phenomenon that the intensity distribution differs according to the wavelength of the laser beam.	Patent No. 2810185
	High-density recording	To improve high-density recording by a multi-value recording system	Writing of a 3-value reflectance according to the amorphous state, the crystal state and the Au deposited state becomes possible by irradiating laser beams of two intensities on an optical disk medium which has a thin alloy film of Au and Si.	Patent No. 2532068
			With phosphorus used for a recording material, heat application turns white phosphorus to red phosphorus. Changing the degree of the heat causes a continuous or stepwise change in thickness, thus improving the recording density.	Patent No. 2601266
			Stable multi-value reproduction levels by comparing a preset pattern signal with its reproduced signal level, controlling a modulation circuit according to the comparison result to thereby control the laser emission condition, such as the recording power or the recording pulse width, and setting the optimal recording	Patent No. 2634827
			Multiplex recording is ensured by forming multiple status-varying portions with different crystallinities and sizes in a phase change recording medium in accordance with the energy of a laser beam.	Patent No. 2642422
			A single recording marker is allowed to contain multiple pieces of information by reducing reflected light at the time of reproduction by narrowing the edge portions of first and second recording markers and the width of the second recording marker.	Jap. Pat. Publ. (Kokoku) No. Hei 8-7882



The high-density recording has been the target since the development on optical disks began, and various solutions have been proposed.

Most of the solutions are associated with the researches on shapes of the recording markers that are the minimum units to represent recording. This popularity seems to have resulted from relatively easier and quicker developments on the markers' shapes that can be achieved by controlling the laser beam.

### (3) Map Portraying Correspondence between Problems and Technologies

This map provides a matrix of technical problems and solvable technologies (including means for achieving, devices and operating principles) for representative patents related to a technology field. It is even more effective to additionally indicate the strength of the solvable technologies by using number of patents. By showing technologies required for problems to solve and considering the technical potential of one's own company, it is possible to estimate the degree of difficulty of realizing a development plan.

#### Case 14: Problems and solutions of technological development of semiconductor lasers (Fig. 25)

Fig. 25 shows the correlation between problems on the

**Fig. 25 Problems and solutions of technological development of semiconductor lasers**

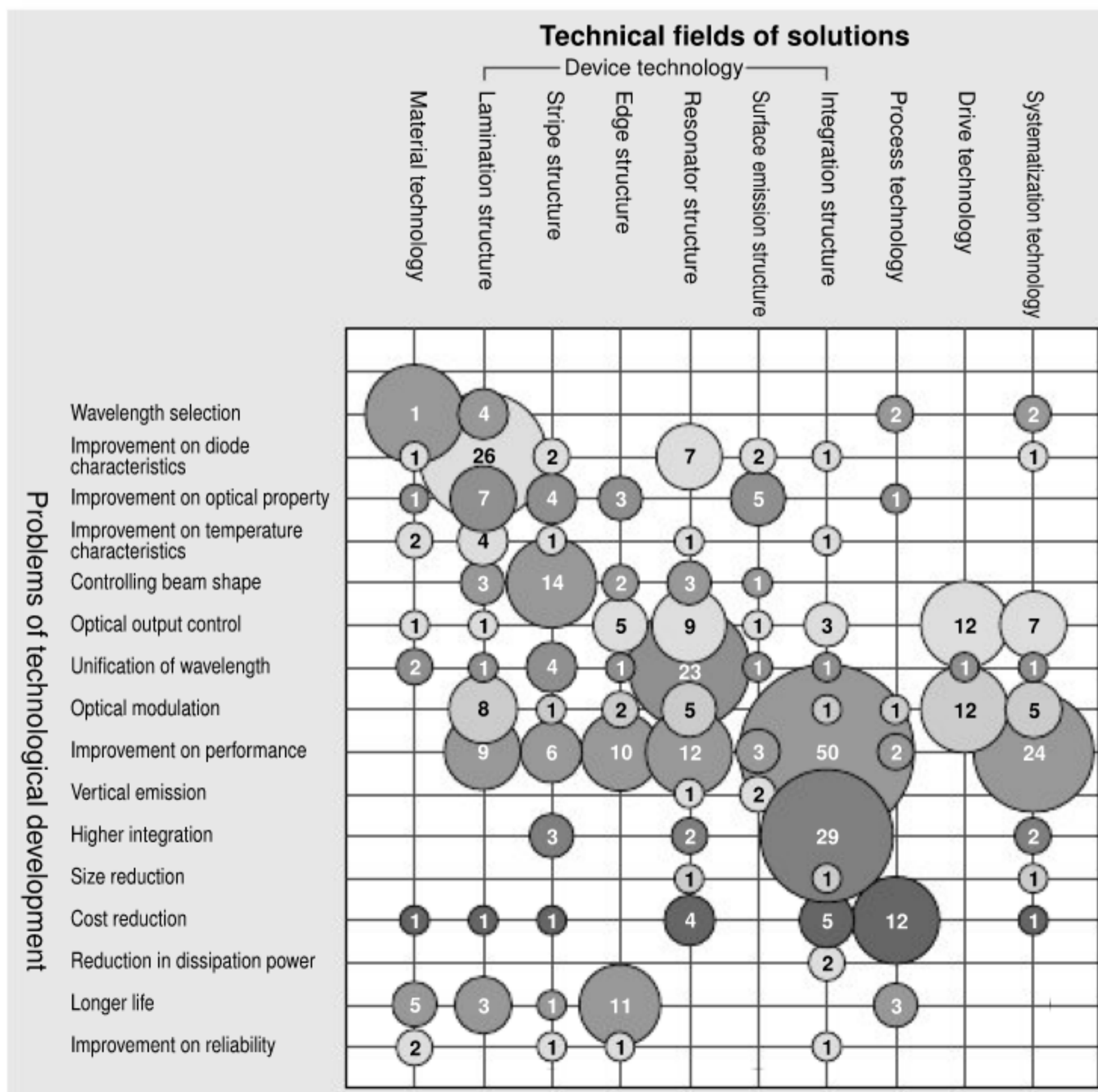

development of the semiconductor laser and the technical fields with which their solutions are associated in terms of the number of typical patents in the last 20 years or so.

As is apparent from this map, the technological development on semiconductor lasers has overcome the technical barriers against practical usage, such as reduced threshold level of oscillation at room temperature, prevention of heat-oriented deterioration, stabilization of the transverse mode, improvement on the higher function and integration, which appeared one after another.

The analysis on the typical patents in the last 20 years or so shows that the technological development was concentrated on the improvement on the higher function.

#### **4. To Know Properties of Applicants** \_\_\_\_\_

In the case of considering to enter in a new business or introducing related patent technology, it is important to observe the overall image of those companies active in the technology field. In addition, since the direction of technological development is affected by the background of the company engaged in development, knowing what industry field that company belongs is important in predicting the direction of technological development. Moreover, looking at the structure of applicants makes it possible to estimate whether or not a field can be easily entered by a small or medium-size company.

Patent maps can indicate information including lists of companies filing large number of patent applications, the industry field of companies filing applications in that technical field, the distribution of patent applications by nationality, patent application trends of government agencies etc.

##### **(1) Map Portraying Applicants Having Filed Many Applications**

This map shows the numbers of patent applications filed by applicants for a specific technology field in decreas-



ing order using a bar graph.

In addition to making it possible to know the main companies in the technical field, this patent map allows to know the status of the entrance of medium and small-size companies as well as foreign companies.

By additionally analyzing the technical specialties of these specific companies and comparing them with the potential of one's own company, this information can be used to select candidates for technical tie-ups and technology grants as well as survey the potential for entering a particular technical field.

**Case 15: Major applicants of laser marking (Fig. 26)**

**Fig. 26: Major applicants of laser marking**

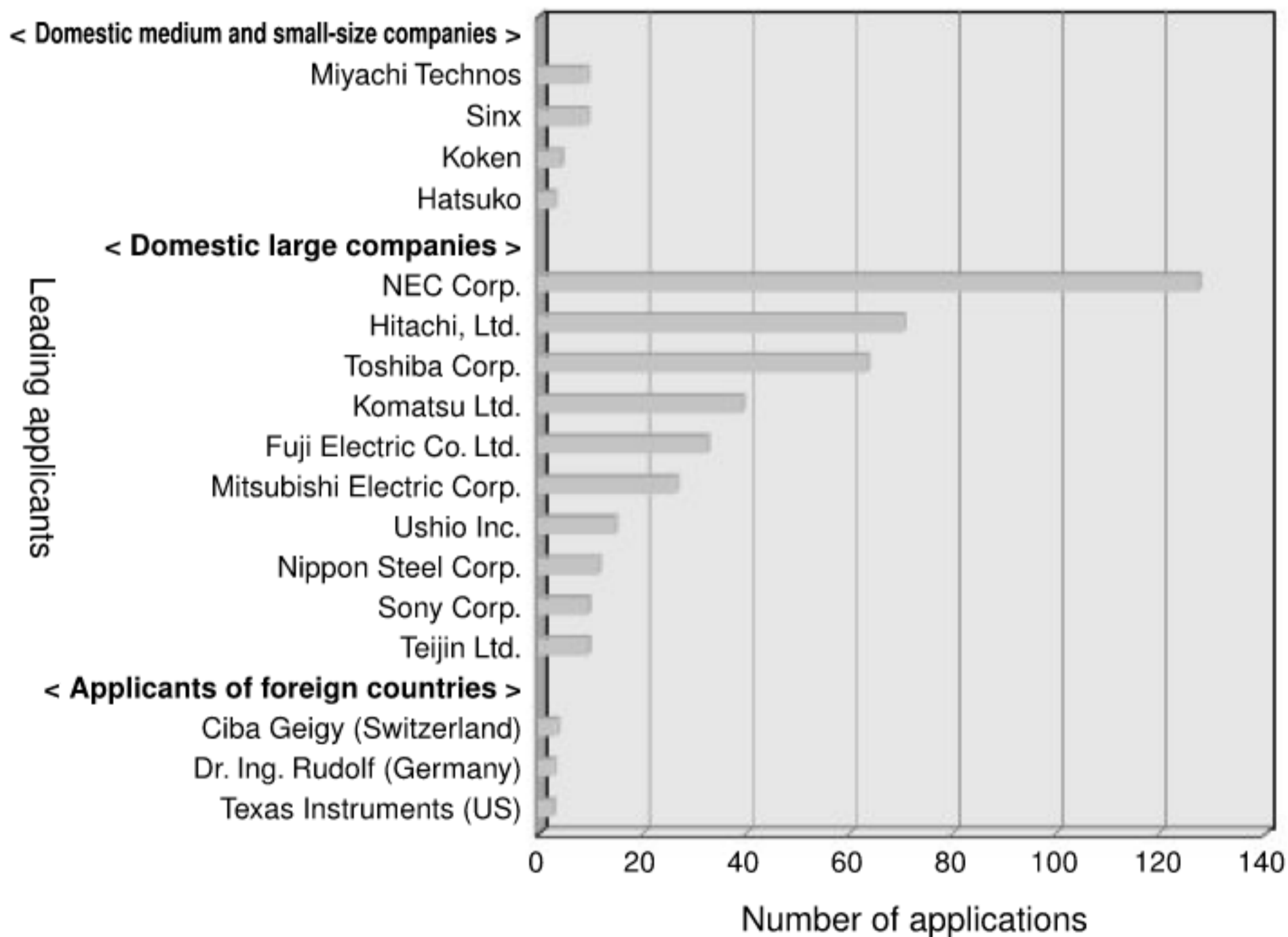

Fig. 26 indicates the names of applicants filing the much numbers of laser marking patent applications while dividing them according to company size.

In looking at those applicants of laser marking patents, electrical manufacturers consisting of NEC Corp., Hitachi Ltd. and Toshiba Corp. account for the top three spots, while

ing order using a bar graph.

In addition to making it possible to know the main companies in the technical field, this patent map allows to know the status of the entrance of medium and small-size companies as well as foreign companies.

By additionally analyzing the technical specialties of these specific companies and comparing them with the potential of one's own company, this information can be used to select candidates for technical tie-ups and technology grants as well as survey the potential for entering a particular technical field.

**Case 15: Major applicants of laser marking (Fig. 26)**

**Fig. 26: Major applicants of laser marking**

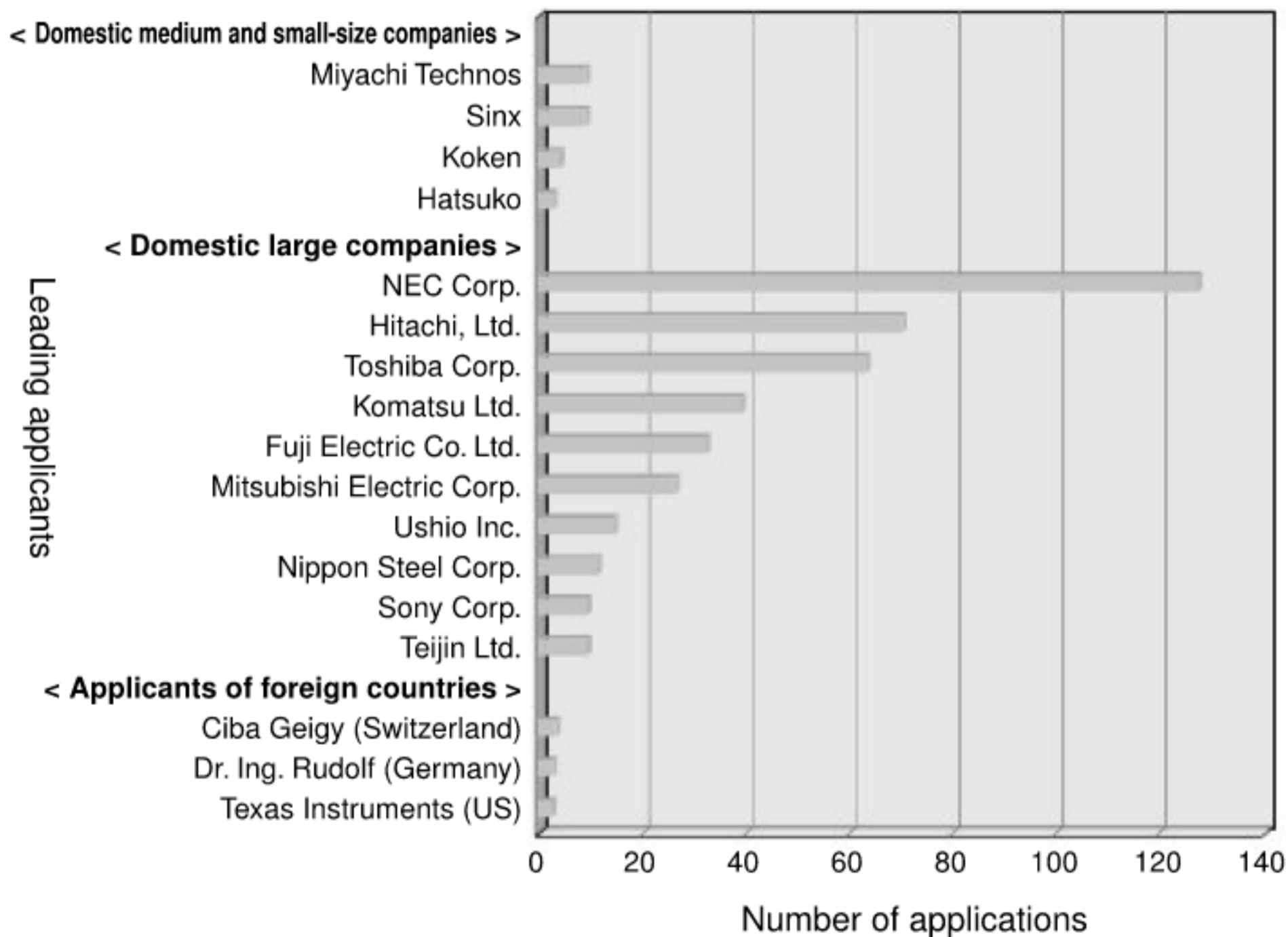

Fig. 26 indicates the names of applicants filing the much numbers of laser marking patent applications while dividing them according to company size.

In looking at those applicants of laser marking patents, electrical manufacturers consisting of NEC Corp., Hitachi Ltd. and Toshiba Corp. account for the top three spots, while

the industrial machinery manufacturer, Komatsu Ltd., is ranked fourth. Other electrical manufacturers such as Fuji Electric Co. Ltd. occupy the fifth through seventh positions. Medium and small-size companies appearing near the top of the rankings include Miyachi Technos and Sinx. Although it can also be seen that the Swiss company of Ciba-Geigy and others appear as foreign applicants, their numbers of patent applications filed are not many.

## (2) Map Portraying Types of Applicants (Individuals, Companies, Government Offices, etc.)

This map shows the number of patent applications and applicants of a technology field for each classification such as individuals, companies, and government offices using a bar graph, polygonal line graph, pie graph or radar chart etc. Among applicants, government offices are promising sources for providing technology. In the case of large numbers of individuals, unlisted companies and medium and small-size companies, that technology field is considered to be easy to enter. Viewing this map is useful in proposing the direction of technological development at one's own company.

**Fig. 27 Percentages of numbers of patent applications by types of applicants relating to AIDS treatment technologies**

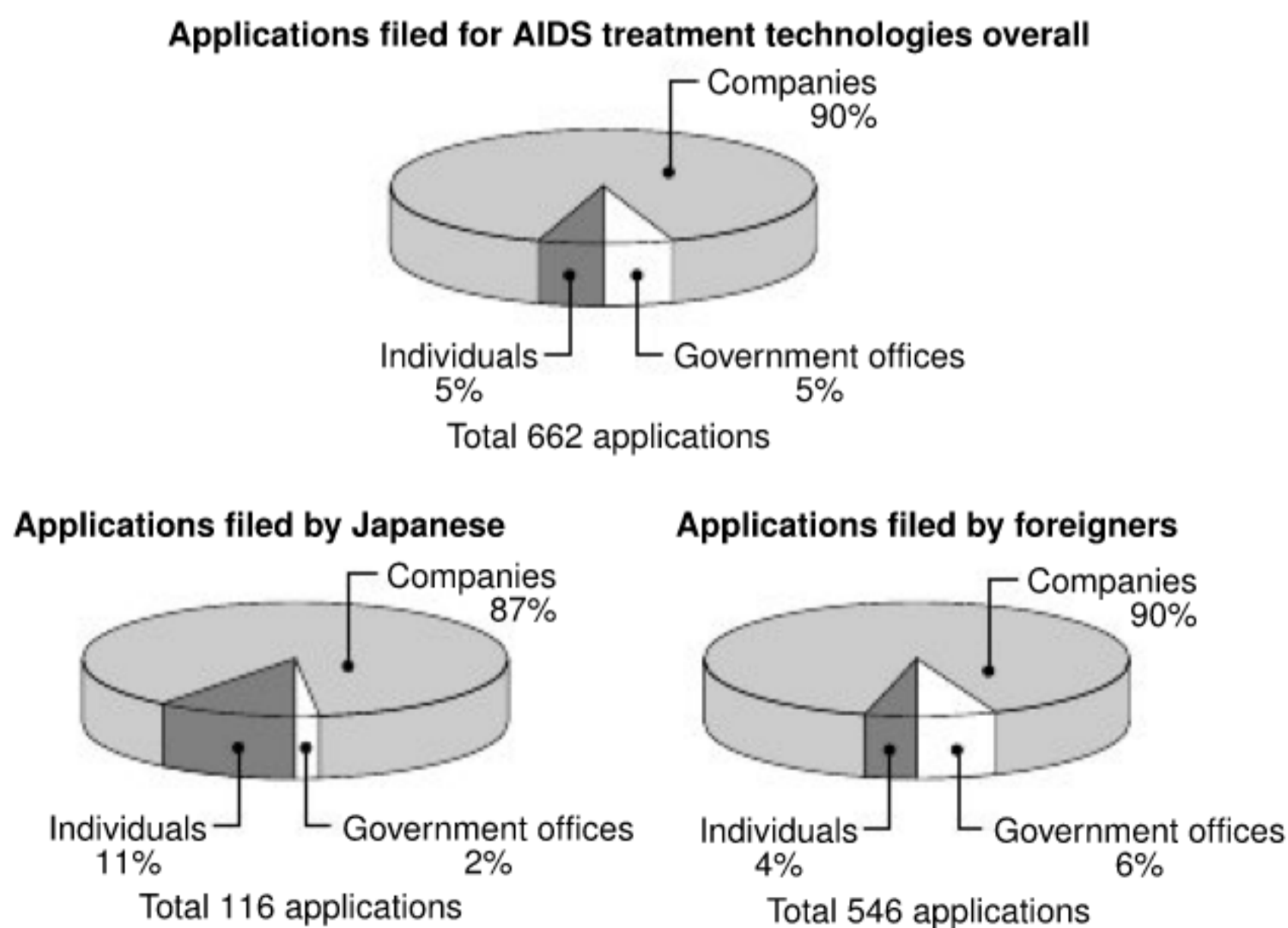

Case 16: Types of applicants relating to AIDS treatment technologies (Fig. 27)

Fig. 27 shows the percentages of patent applications filed relating to AIDS treatment technology in major uses of immuno therapy according to the type of applicant.

According to this figure, the number

of applications by individuals (such as university professors) is relatively large among applications filed by Japanese, while among applications filed by foreigners, the number of applications filed by government offices is relatively large.

On the basis of these findings, it can be seen that, with respect to serious social problems like AIDS, technological development is performed by universities and government offices, and in foreign countries in particular, governments exhibit strong leadership.

### (3) Map Portraying Numbers of Applications According to the Nationalities of Applicants

This map indicates the number of patent applications according to nationality that were filed by a foreign entity in Japan. In addition, the same method may be used to indicate the number of applications filed for US and European patents as well. Examples of methods for expressing this information include indication of the percentages of applications using a pie graph, and indication of the changes in number of applications filed using polygonal line graphs and bar graphs.

In the case of indicating the numbers of patent applications filed by nationality with a pie graph, the degree of entry into the Japanese and overseas markets can be known for each country. In the case of indicating changes in the numbers of applications filed, trends relating to entrance and withdrawal from a particular field can be known. This map makes it possible to judge the degree of entrance into the Japanese market by overseas manufacturers as well as the overseas trends of prominent manufacturers. This can be used to make timely managing judgments regarding the development of competitive products, technical tie-ups etc.

### Case 17: Acquisition status by country of US patents relating to semiconductor lasers (Fig. 28)

Fig. 28 shows the results of classifying applicants of US patents relating to semiconductor lasers according to nation-

**Fig. 28 Acquisition status by country  
of US patents relating to semiconductor lasers**

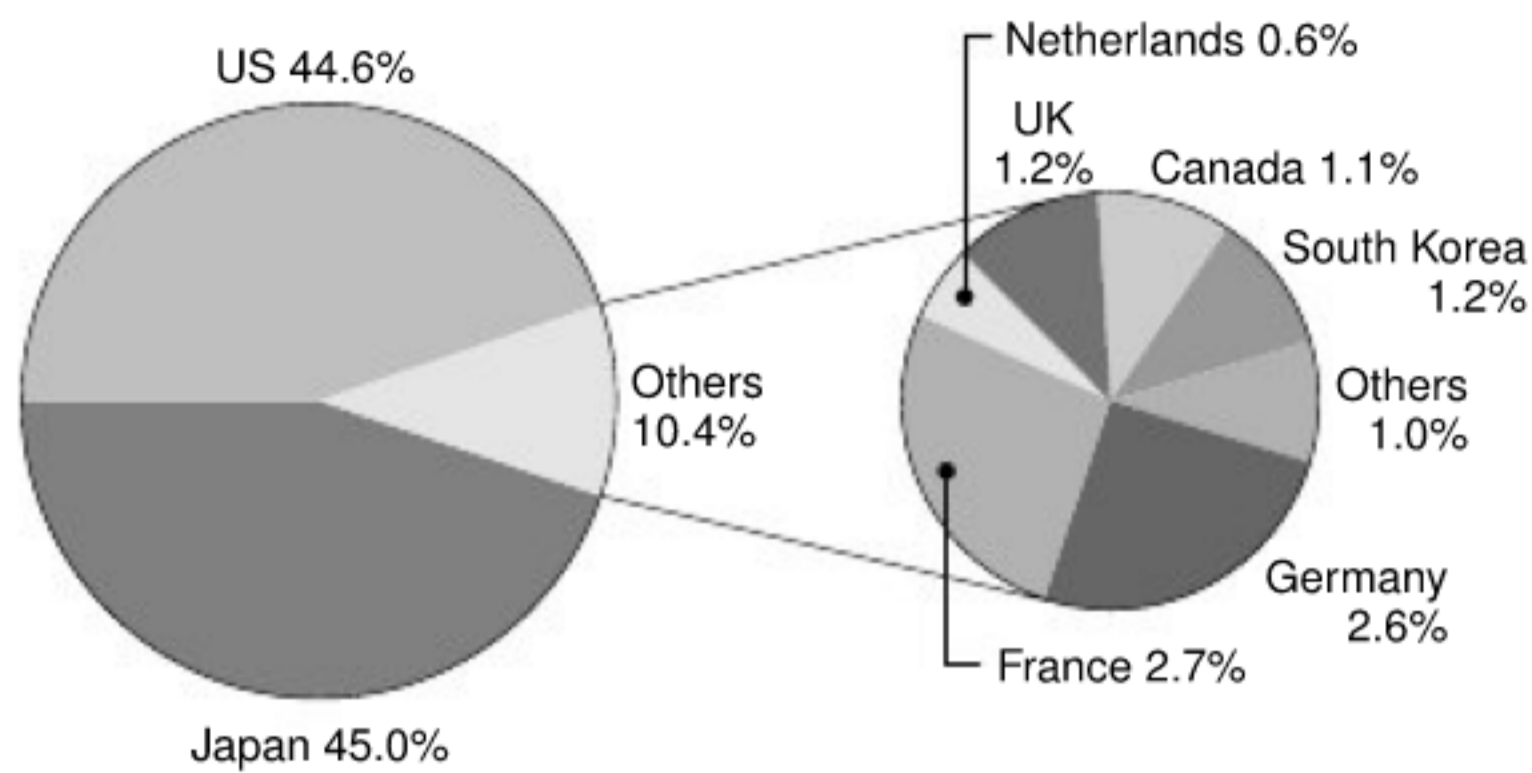

ality. What is noteworthy in this figure is that 45% of the patent applications are from Japan. This percentage is equal to the percentage of applicants of US nationality, and indicates that US patents are nearly shared between Japan and the US in two halves.

Since countries other than the US and Japan such as France, Germany, UK, Canada and South Korea account for 1-2% each, the percentage of Japanese US applications can be seen to be extremely large with respect to applications from countries other than the US. Incidentally, although there are cases in which European companies, such as Phillips of the Netherlands, file US patents through their US subsidiaries like Phillips USA, even when considering this point, the number of Japanese patent applications filed in the US still account for an extremely high percentage in comparison with other countries filing patent applications in the US.

#### (4) Map Portraying Composition of Applications by Industry Type

This map shows the numbers of applicants or patent applications using a pie graph or bar graph and so forth by classifying applicants of a specific technology field according to industry type. This map makes it possible to consider whether a target technology field is an oligopolistic field in which a specific industry type plays a leading role, or a field in which there are few barriers to entrance and various industry types coexist.

#### Case 18: Composite ratios of industry types for major applicants (Figs. 29 and 30)

Figs. 29 and 30 show the percentages of the numbers of

**Fig. 29 Composite ratios of industry types for major applicants from 1977 to 1979**

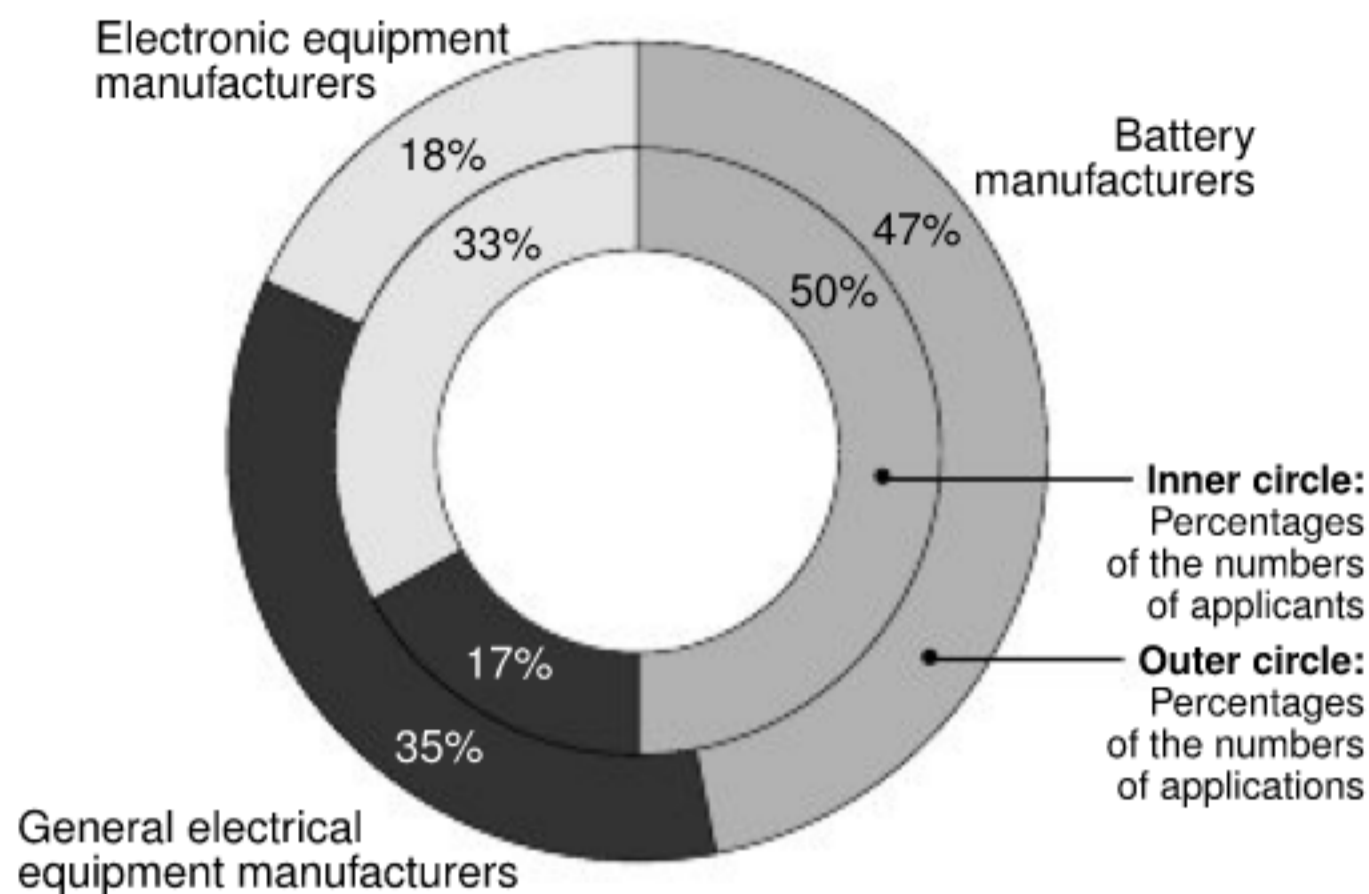

**Fig. 30 Composite ratios of industry types for major applicants from 1995 to 1997**

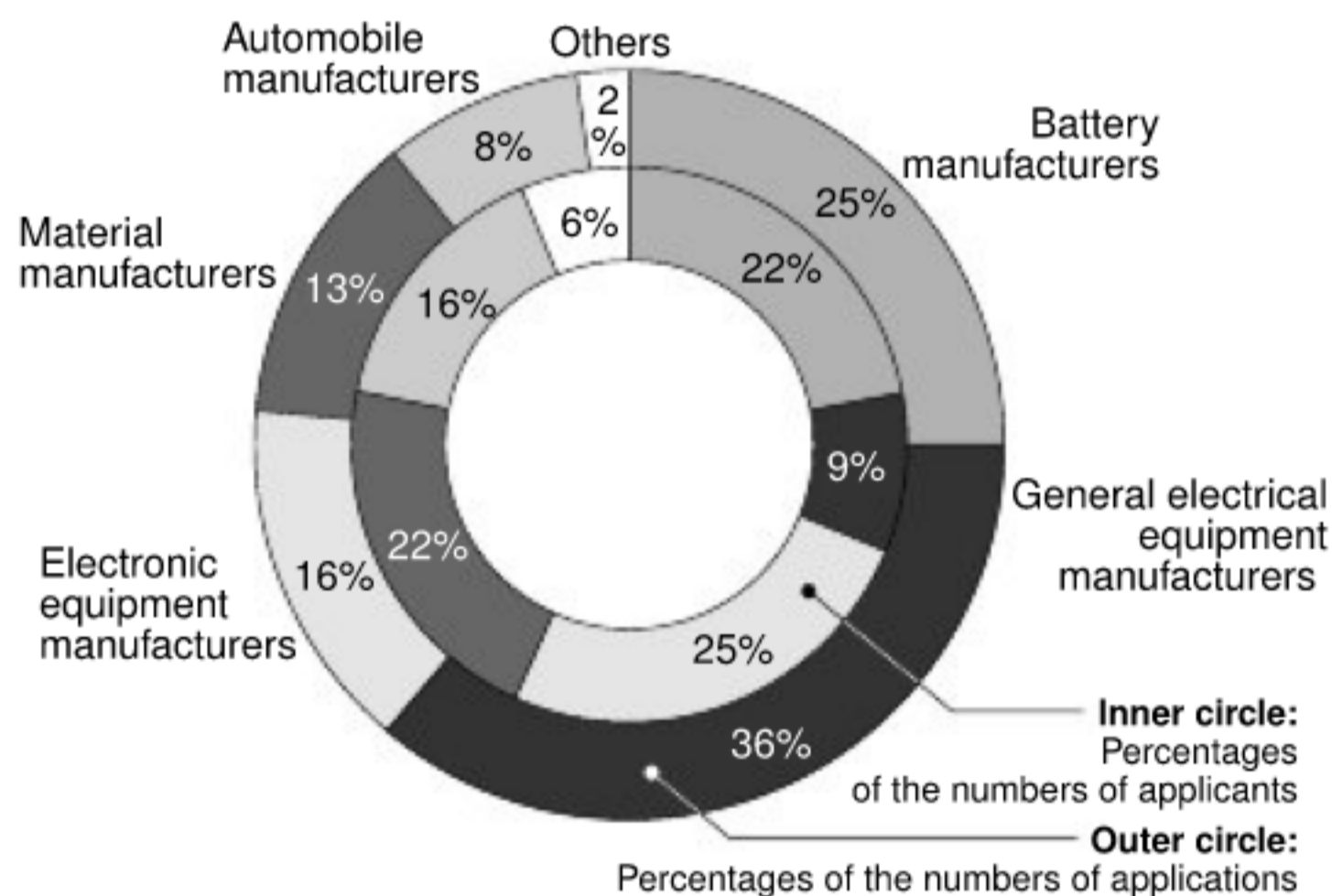

applicants on the inner circle of a pie graph, and the percentages of numbers of applications filed on the outer circle by classifying applicants for secondary batteries according to industry type.

Twenty years ago, major applicants consisted only of battery manufacturers, general electrical equipment manufacturers and electronic equipment manufacturers. Recently however, due to the entrance of material manufacturers, automobile manufacturers and others, these manufacturers have come to account for 44% of major applicants in terms of the number of applicants and 23% in terms of the number of applications.

On the other hand, the percentage of battery manufacturers had dropped considerably from 50% to 22% in terms of the number of applicants, and from 47% to 25% in terms of the number of applications. However, even though the percentage of general electrical equipment manufacturers has decreased from 17% to 9% in terms of the number of applicants, in terms of the number of applications, the percentage has increased, although only slightly, from 35% twenty years ago to the current level of 36%.

## 5. To Deal with the Globalization of Business

Economic activities of the twenty first century are required to take into perspective not only the domestic market, but a wide range of overseas markets as well.

Patent maps can be used to analyze patent application filing trends in the US and Europe, as well as provide a detailed analysis of filing trends for specific technology field in a drastic international competition.

(1) Map Portraying Structural Differences of Applications among the US, Europe and Japan

This map shows differences in filing structure in the US, Europe and Japan by analyzing the number of patent applications and number of applicants relating to a specific technology field using various characteristics of applicants.

Examples of applicant characteristics that are used include classification of applicant type such as an individual, company or government office, classification of industry type such as electricity, machinery or chemicals, and classification of corporate size such as a venture company, medium or small-size company or large company.

It is sometimes necessary to utilize information other than patent information, as in the case of classifying into industry type or company size, in order to make these classifications.

**Case 19: Composition of number of applicants by industry type related to genetic engineering (Fig. 31)**

Fig. 31 shows the percentage of the number of applicants by applicant type such as university/research institutions, venture companies and chemical companies for Japanese applicants of Japanese patents and all applicants of US patents.

It can be seen from this figure that, in contrast to Japanese applicants of Japanese patents being characterized by technology development primarily by manufacturers such as chemical companies, pharmaceutical companies, food manufacturers and breweries, the majority of applicants of US patents are universities and research institutions, indicating that the emphasis is placed on basic research of genetic

**Fig. 31 Composition of number of applicants by industry type related to genetic engineering**

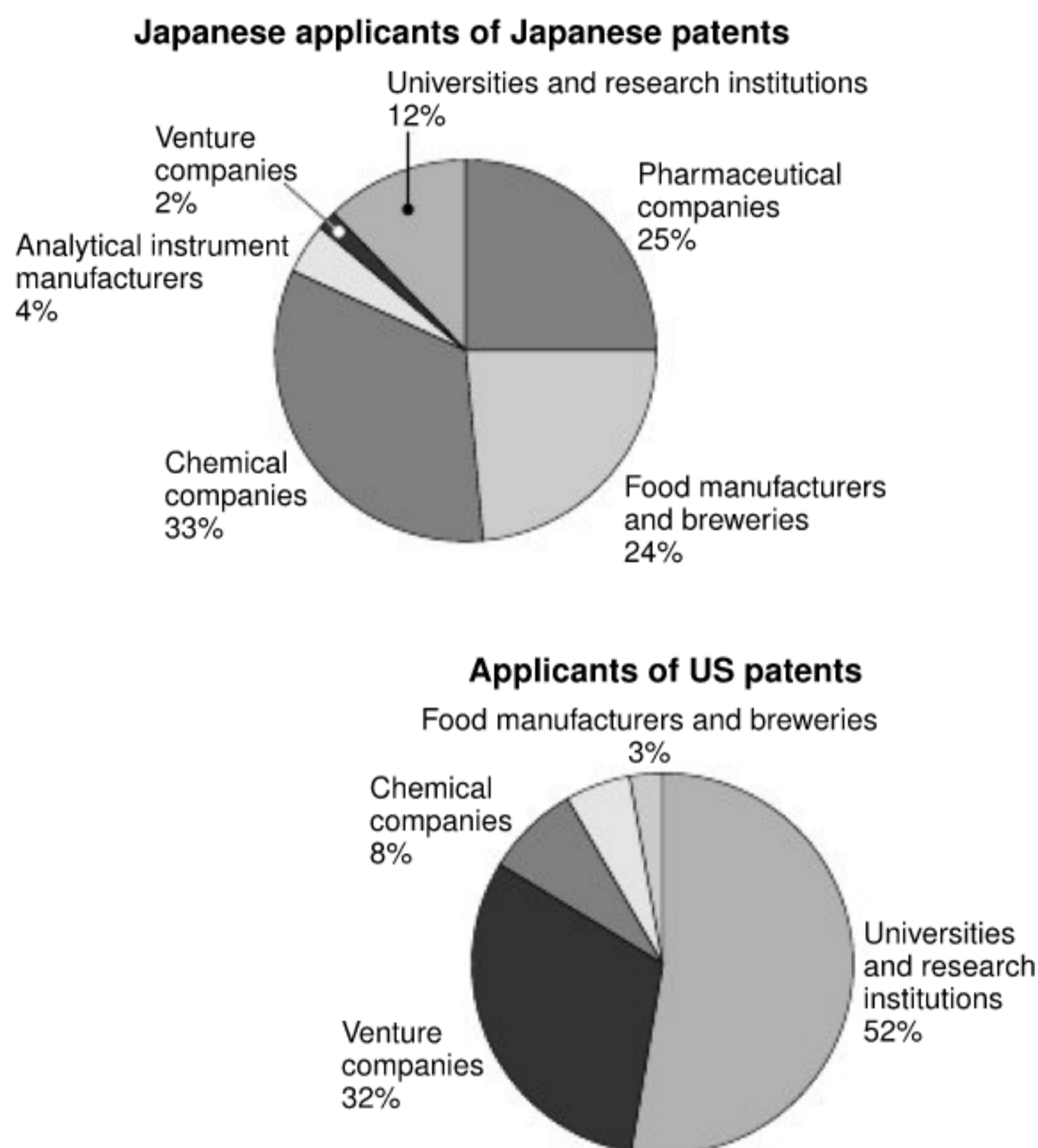

engineering.

### (2) Map Portraying Upper Ranked Applicants (Right Holders) of Foreign Countries

This map shows the applicants relating to a specific technology field in descending order of the number of patent applications. This makes it possible to know the names of main companies specializing in that field, while also identifying competitors and possible companies for technical tie-ups on overseas markets.

### Case 20: Top ranking applicants for online shopping in the US and Japan (Fig. 32)

Fig. 32 is a list of the applicants in the descending order of patent applications for US patents relating to online shopping.

As is indicated in this list, prominent companies in this field on the US market include IBM, Hitachi, Fujitsu and Microsoft. By comparing the strong technologies and weak technologies of one's own company with those of these prominent companies, it is possible to focus on competitors and possible companies for technical tie-ups in the case of entering the US market.

### (3) Map Portraying Expanses of a Technology Development in Foreign Countries

This map shows the mutual relationship of core patents relating to a specific technology field while focusing on tech-



**Fig. 32 Top ranking applicants for online shopping in the US and Japan (excerpt of US patents only)**

U.S.	
Number	Applicant
39	Unassigned or assigned to individual(*)
16	International Business Machines
9	Hitachi (Japan)
7	Fujitsu (Japan)
6	Microsoft
6	Electronic Data Systems
5	Pitney-Bowes
4	Digital River
3	Oracle
3	Clear With Computers
3	Casio Computer 5 (Japan)
3	Sun Microsystems
3	AT & T Global Information Solutions
3	Anderson Consulting

\* Individual registration but different persons

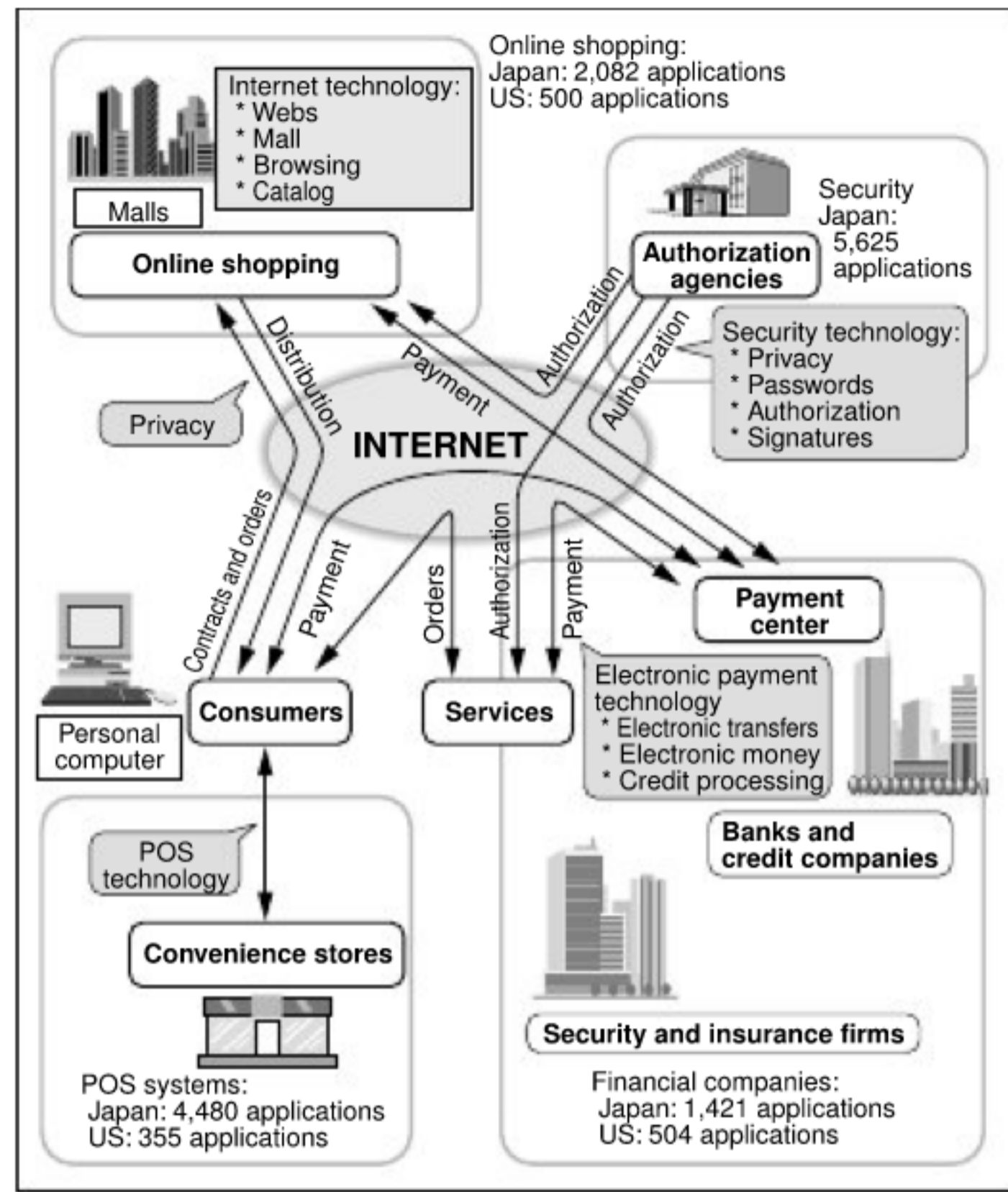

nical characteristics, filing dates, cited references etc. There are many cases in which core patents are arranged chronologically.

As a result, overseas technology trends can be estimated and used as hints for the planning and proposal of new products. In addition, knowing the source of a technology can be used as information that provides hints for creating new ideas.

**Case 21: Map concerning invoice and payment technology field (Fig. 33)**

Fig. 33 shows chronologically the technical characteristics of key patents in Japan and the US relating to invoice and payment technology field which constitutes the main field of electronic commerce. These technical characteristics were extracted by scanning the entire patent information.

In this field, although a patent application was first filed in Japan for technology relating to payment settlement of



According to this figure, USP 5,556,752 (Affymetrix) is cited in 6 patent applications, USP 5,578,832 (Affymetrix) is cited in 3 patent applications, and USP 5,632,957 (Nanogen) is cited in 1 patent application.

Analysis of the technology fields of the citing patents makes it possible to view the expanse of technology fields, thereby providing a clue for new inventions and ideas in various uses.

## 6. Examples of Combination of Patent Maps

The followings are examples combined with more than one patent map in order to show what can be actually observed.

**Figure 35 Uses of highly functional fibers**

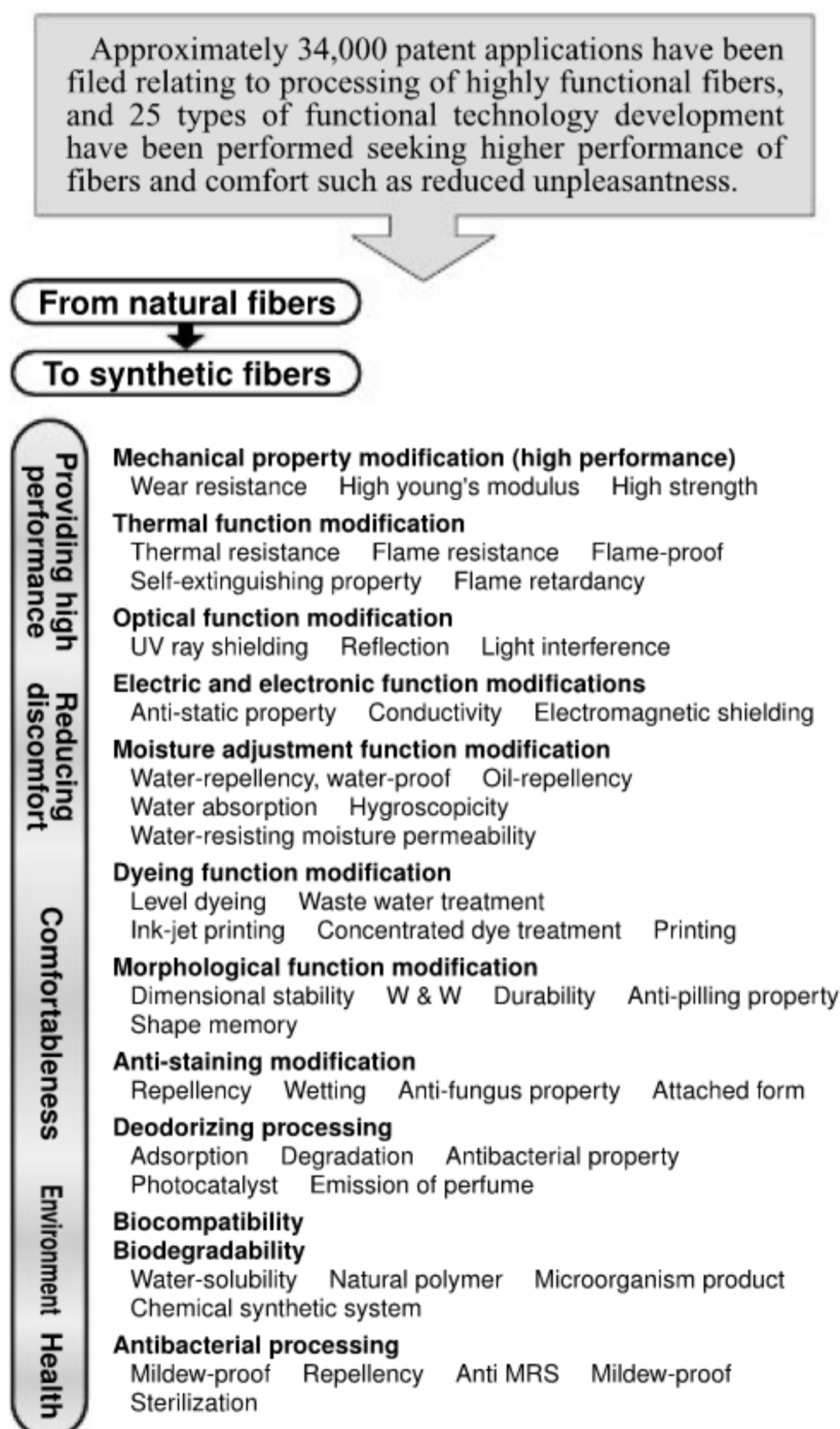

Case 1: - Exploring market (consumer) needs -

<Functional fiber processing>

Following the Second World War, the development of synthetic fibers such as Nylon and polyester fibers started, taking the place of natural fibers.

Fig. 35 shows technological development from various functional fibers for industrial applications to fibers reduced unpleasantness for consumer applications. This was followed by inventions of a variety of functional fibers which were stimulated by the development toward new fashionable fibers.

In addition, according to Fig. 36, when looking at 25 functions of fibers processing according to their individual

**Figure 36** Number of applications of highly functional fibers by production process

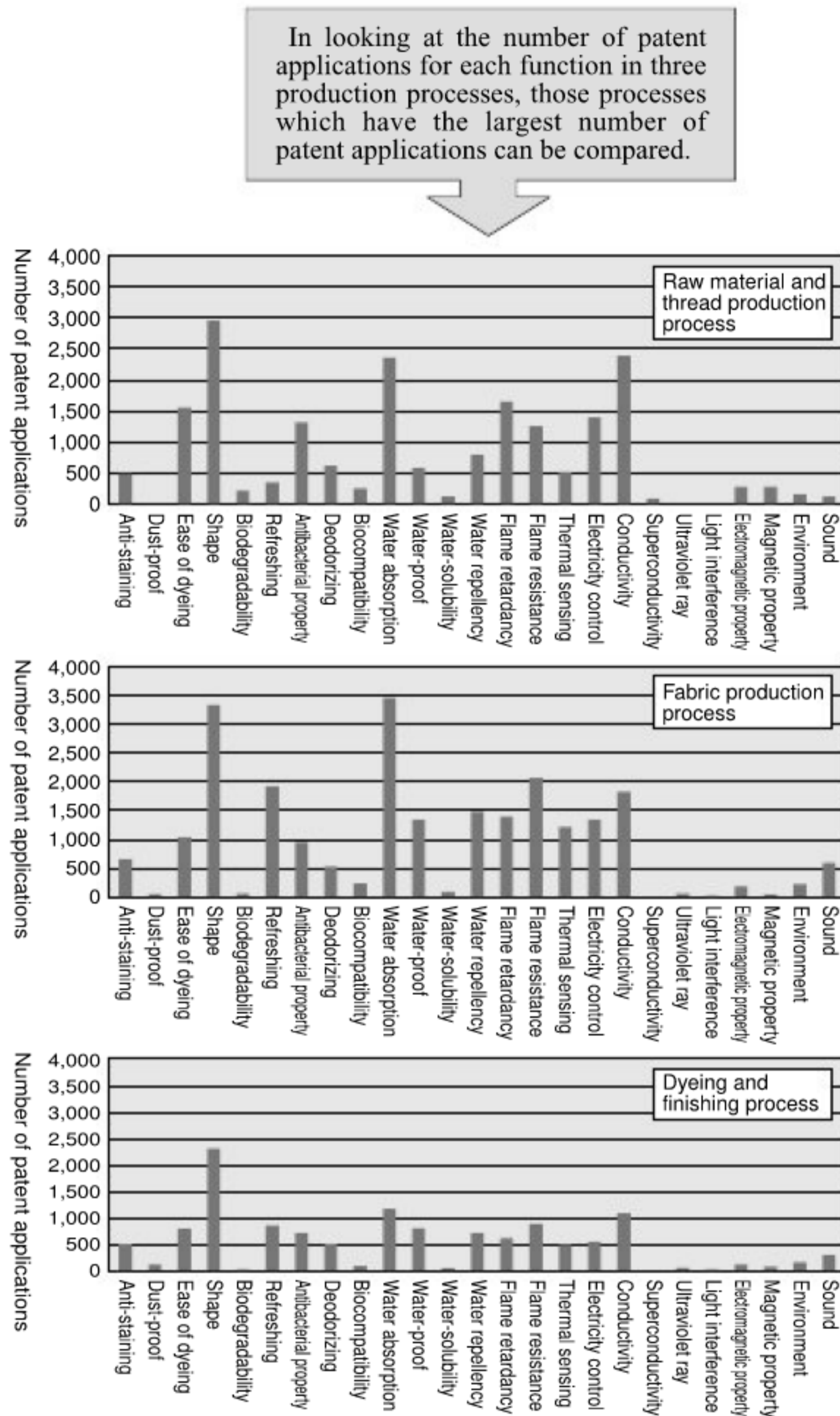

processes, a large number of patent applications can be seen to have been filed in the initial processes involving raw materials and thread production (spinning).

In the past, many functional fibers were formed by woven fabrics, fiber surface improvements, and the surface covering of knitting. Internal improvement of fibers and technology for imparting various functions in the thread and spinning processes increased, and diverse applications to ultrafine fibers, porous fibers and hollow fibers became conspicuous. This trend was particularly prominent in terms of effects demonstrated by focusing on the materials, examples of which

include electrical conductivity, flame resistance, antibacterial properties and ease of dyeing. On the other hand, technological development attempted to find ways to achieve advantages in terms of health, environment and comfort, and a diverse range of functions were combined, such as moisture absorption/water-resistant moisture permeability and antibacterial deodorizing, anti-static and deodorizing, water-resistant moisture permeability and flame resistance, resulting in development of textile of higher quality level.

**Figure 36** Number of applications of highly functional fibers by production process

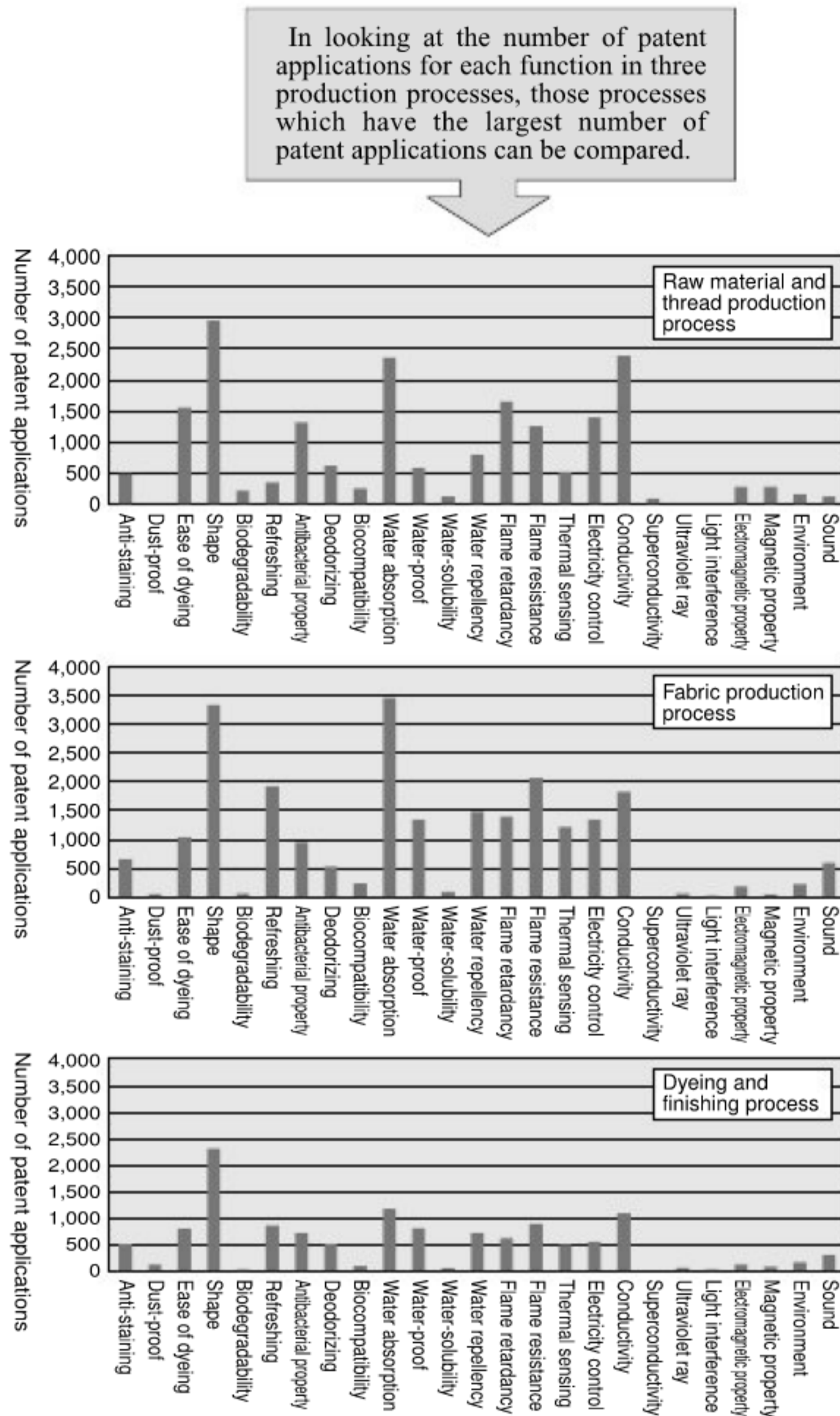

processes, a large number of patent applications can be seen to have been filed in the initial processes involving raw materials and thread production (spinning).

In the past, many functional fibers were formed by woven fabrics, fiber surface improvements, and the surface covering of knitting. Internal improvement of fibers and technology for imparting various functions in the thread and spinning processes increased, and diverse applications to ultrafine fibers, porous fibers and hollow fibers became conspicuous. This trend was particularly prominent in terms of effects demonstrated by focusing on the materials, examples of which

include electrical conductivity, flame resistance, antibacterial properties and ease of dyeing. On the other hand, technological development attempted to find ways to achieve advantages in terms of health, environment and comfort, and a diverse range of functions were combined, such as moisture absorption/water-resistant moisture permeability and antibacterial deodorizing, anti-static and deodorizing, water-resistant moisture permeability and flame resistance, resulting in development of textile of higher quality level.

## Case 2: Clean environment is today's vital need

### <Functional Plastics>

Figs. 37 and 38 are examples of new materials that were

**Fig. 37 Number of patent applications and applicants for biodegradable plastics**

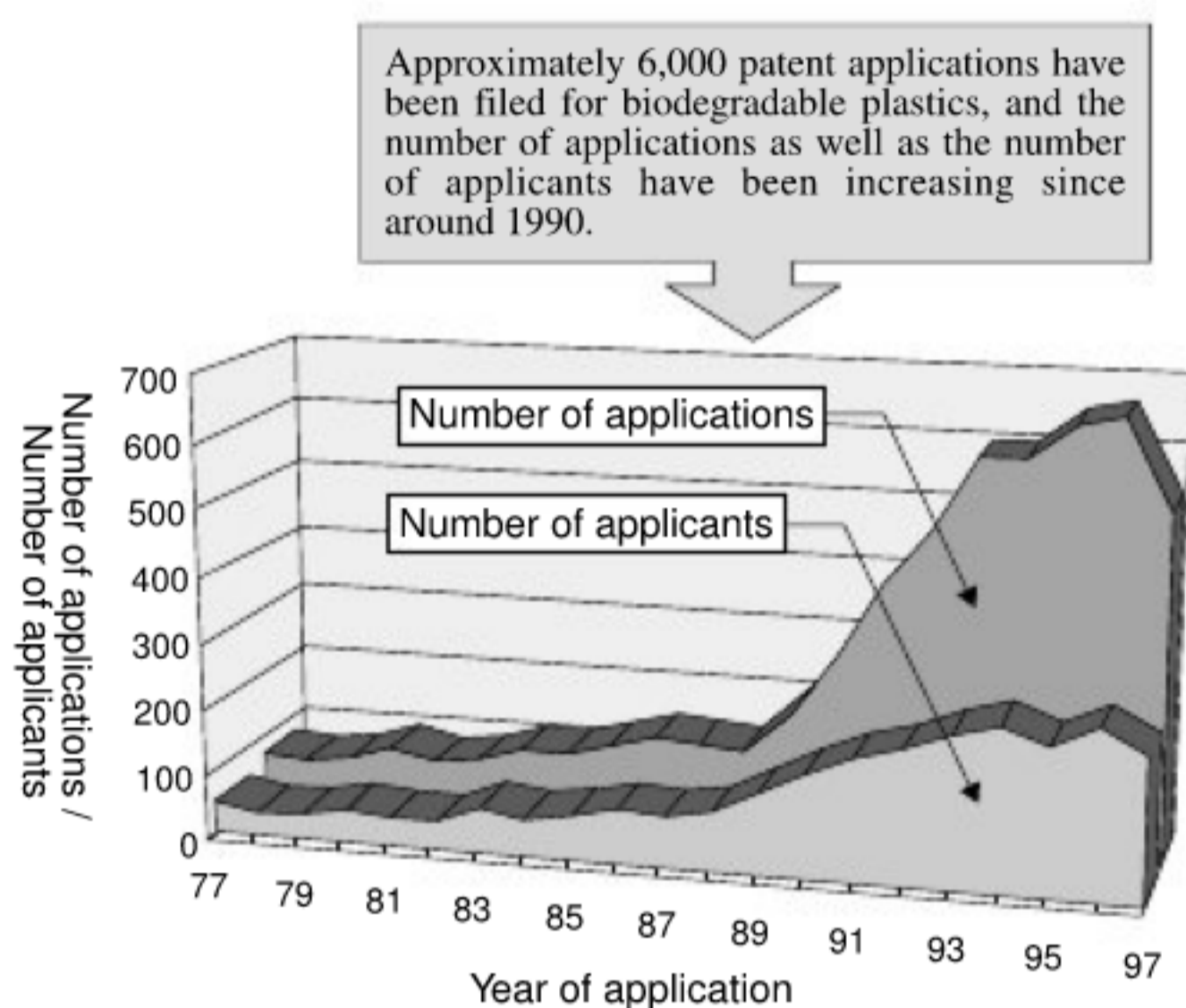

**Fig. 38 Technology categories of biodegradable plastics patents**

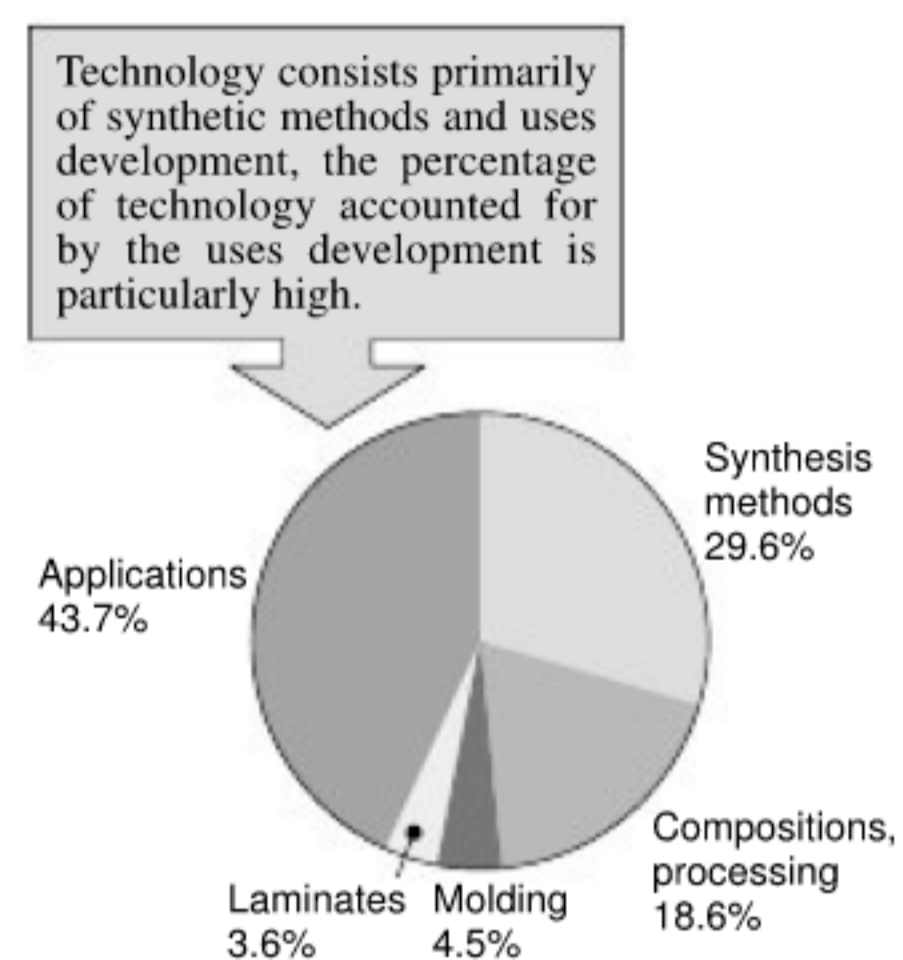

born out of concern over environmental problems. Full-scale research on biodegradable plastics began just over ten years ago, and the number of patent applications have increased rapidly. New synthetic methods and market exploitation lie at the center of this development.

Fig. 39 shows that the development has been turned to agricultural uses and packaging materials related to home garbage containers.

## Case 3: To search business opportunities

### <Bio remediation>

Fig. 40 is an example of new technology field that solves the problem of environmental contamination using the natural capabilities of microorganisms. The number of patent applications has increased rapidly since around 1993 as a treatment technology that creates little concern over secondary contamination caused by chemical substances.

It can be seen from Fig. 41 that reduction of treatment time, improvement of reaction controllability and bio-safety,

**Fig. 39 Typical applications of biodegradable plastics**

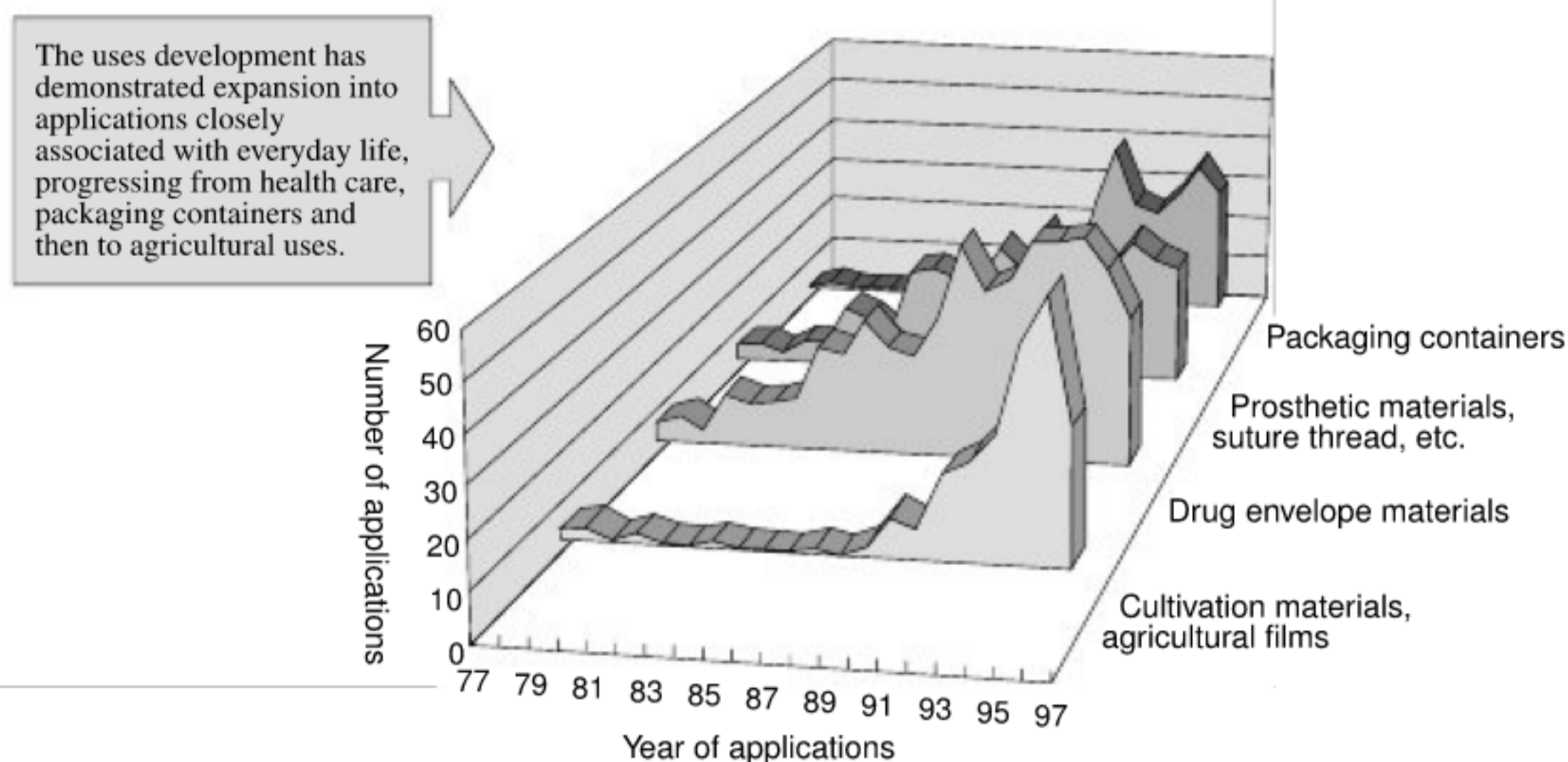

**Fig. 40 Number of applications for bio remediation related to contaminated soil**

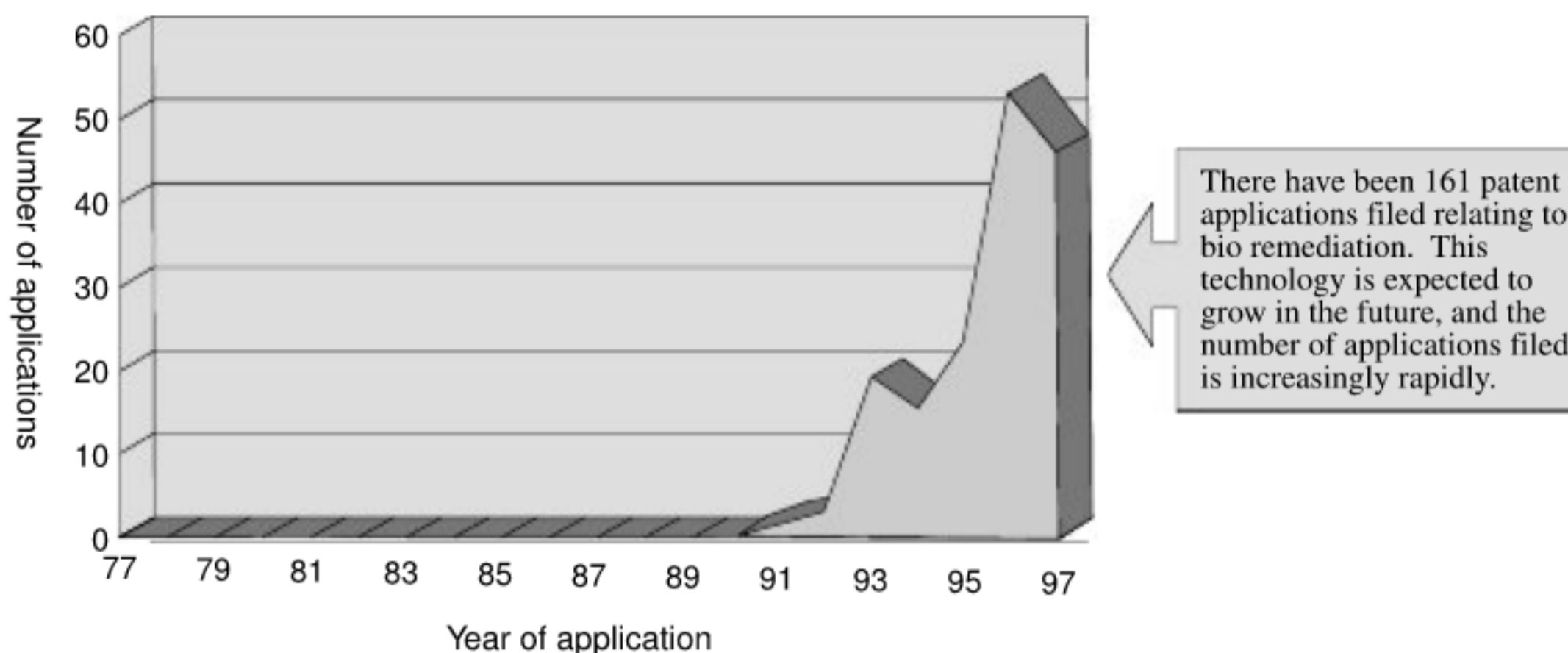

and treatment of highly concentrated contaminating substances are problems to be solved in the future.

#### Case 4: To know main industry type <Superconductivity>

Fig. 42 shows the major developers of superconductivity technology field according to the industry types of the applicants. It can be seen that the development of superconductivity technology has been led by the electrical machinery and steel/metal industry fields.

Figs. 43 and 44 show the kinds of technological devel-

**Fig. 41 Target substance and technology related to bio remediation**

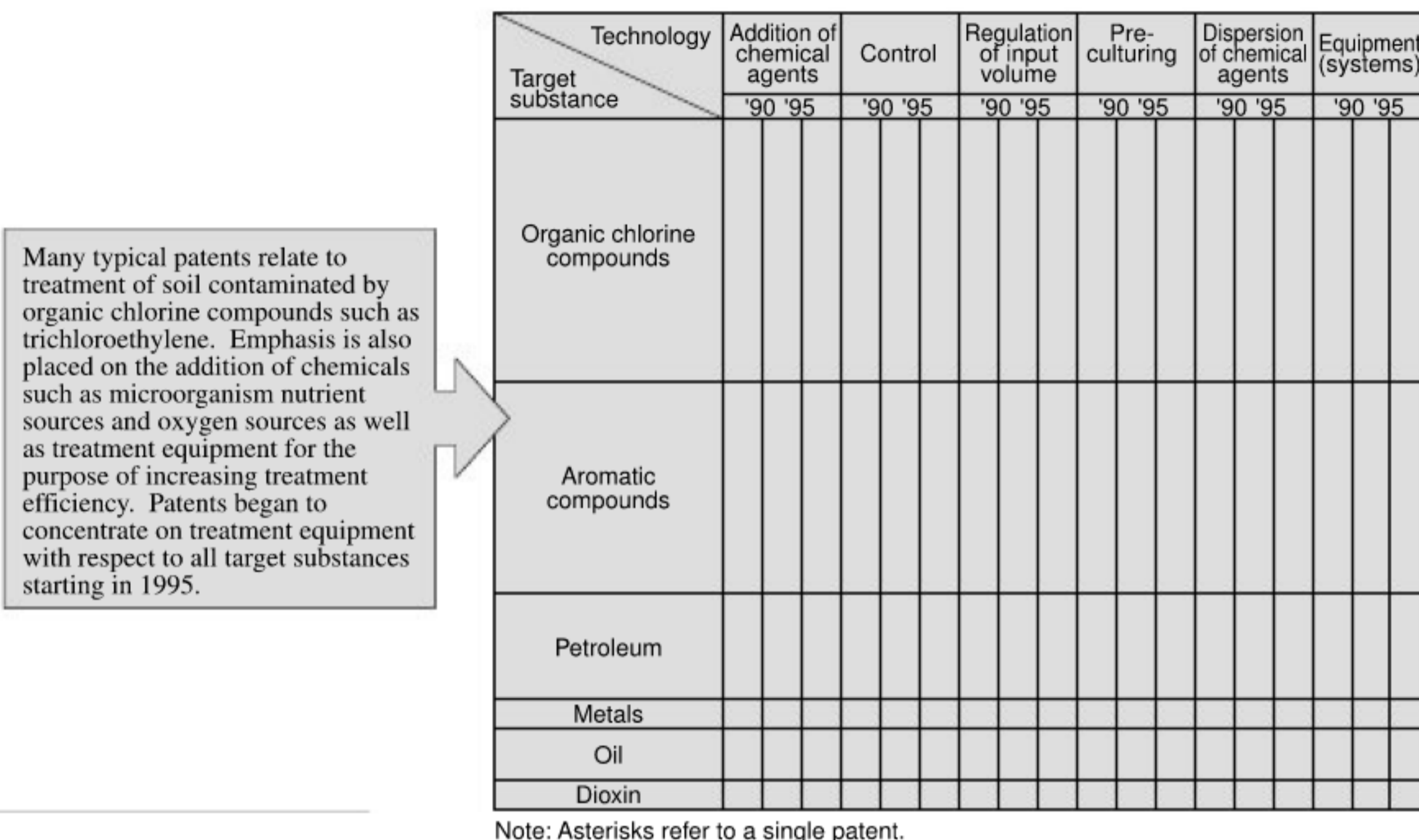

**Fig. 42 Number of applications of superconductivity technology by industry type (1977-1997 applications)**

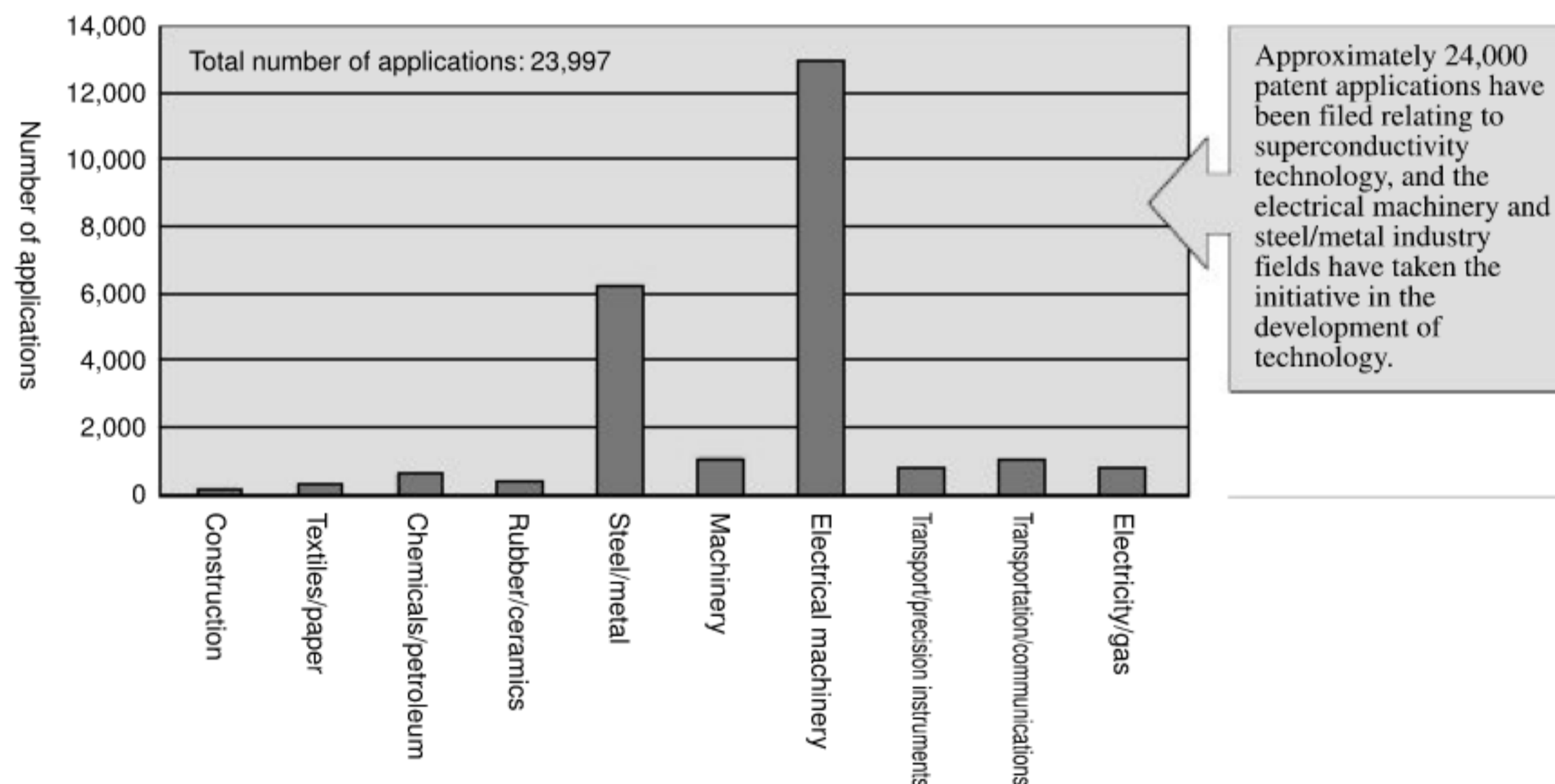

opment pertaining to superconductivity in the electrical machinery and steel/metal industry fields, respectively.

In the electrical machinery industry field, for example, although the ratio of elementary technology to applied technology is 6:4, in the steel/metal industry fields, the ratio of elementary technology to applied technology is 8:2, thus indicating that technology development is being conducted



**Fig. 43 Kinds of technological development in the electrical machinery field (1977-1997 applications)**

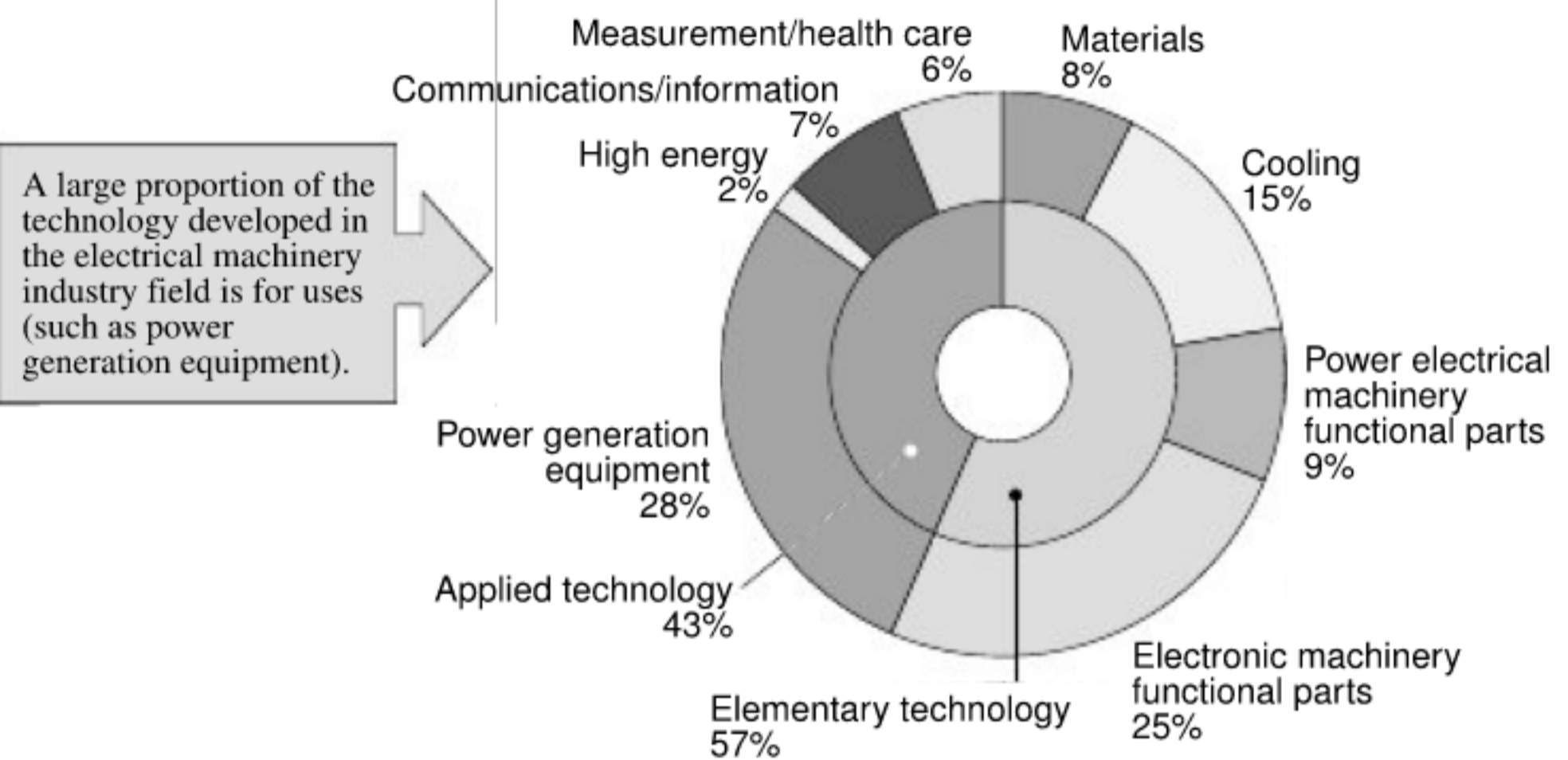

**Fig. 44 Kinds of technological development in the steel/metal industry fields (1977-1997 applications)**

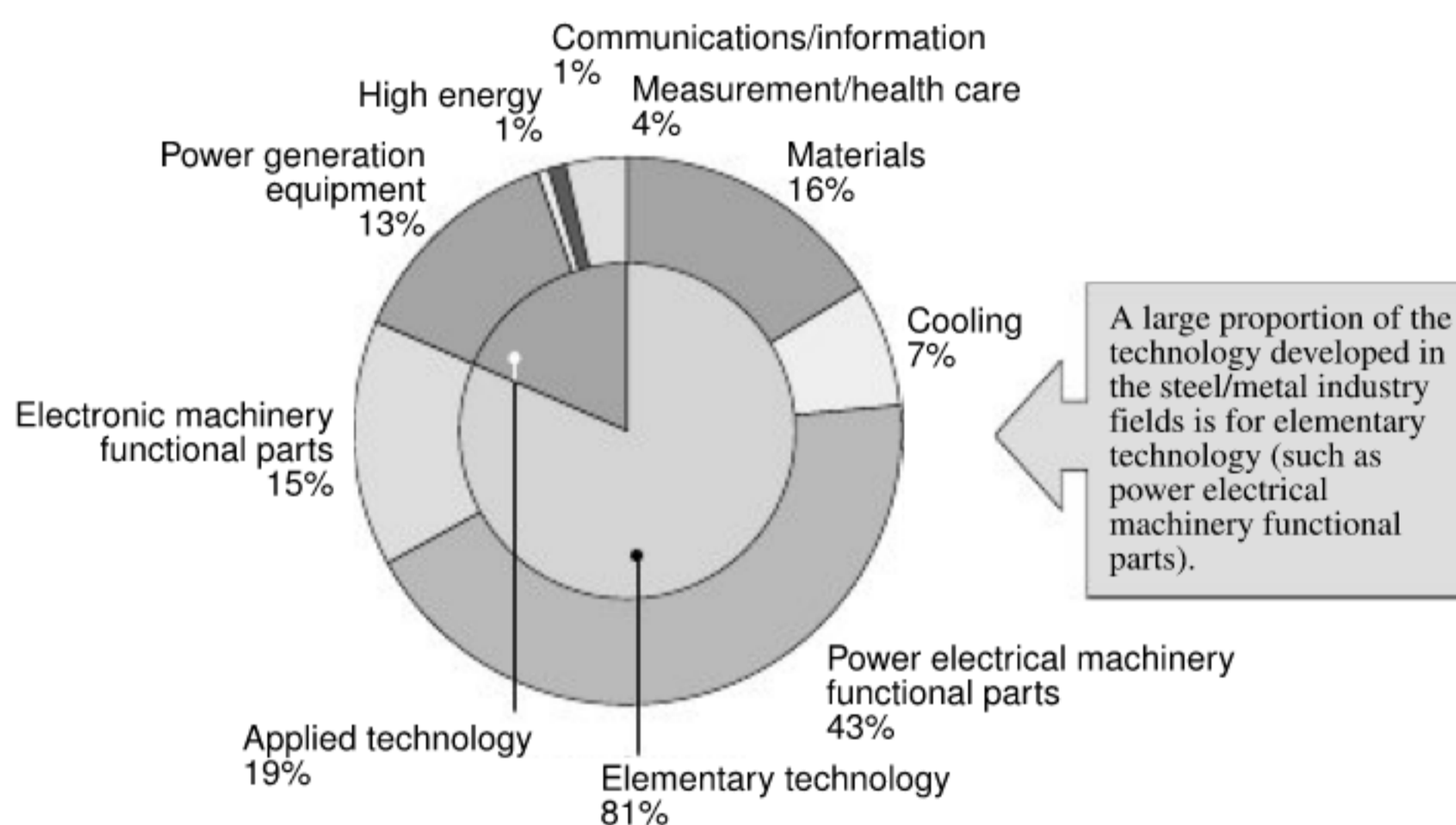

focusing primarily on elementary technology.

**Case 5: - To deal with the globalization of business- <Genetic Engineering>**

It can be seen from Fig. 45 that US patent applications relating to genetic engineering began to be filed around 1974, increased rapidly starting in 1980, and have continued to demonstrate an increasing trend since that time.

Fig. 46 shows that in the US, the majority of those patent applications were filed by universities and research

**Fig. 45 Number of US patent applications related to genetic engineering**

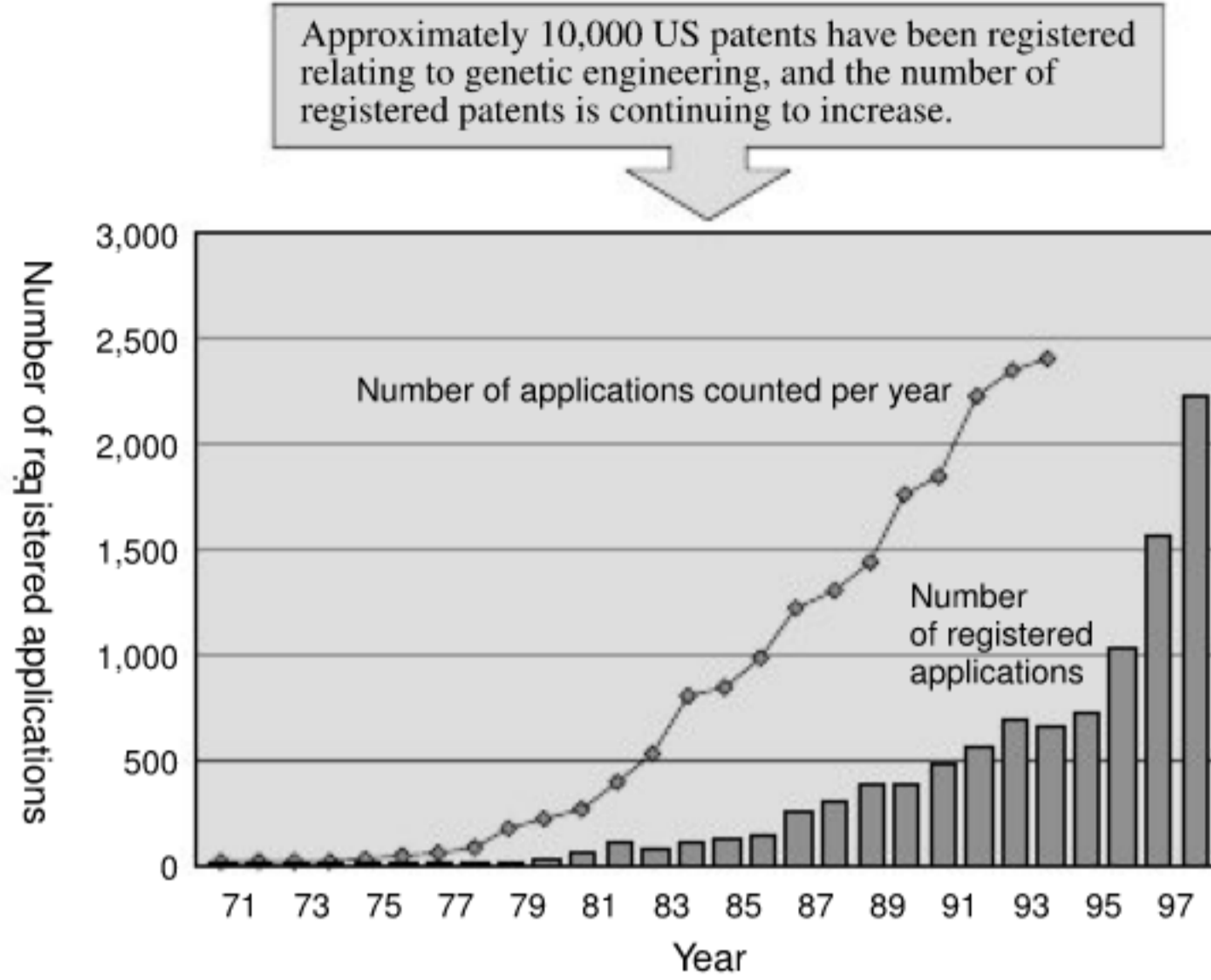

institutions, and that the emphasis is placed on basic research. The large number of venture companies is also characteristic of the US.

It can be determined from Figs. 47 and 48 that US entities account for the majority of patent applications in Japan, illustrating the aggressive patent strategies by US entities.

**Fig. 46 Percentages of numbers of US patent applications by types of applicants related to genetic engineering**

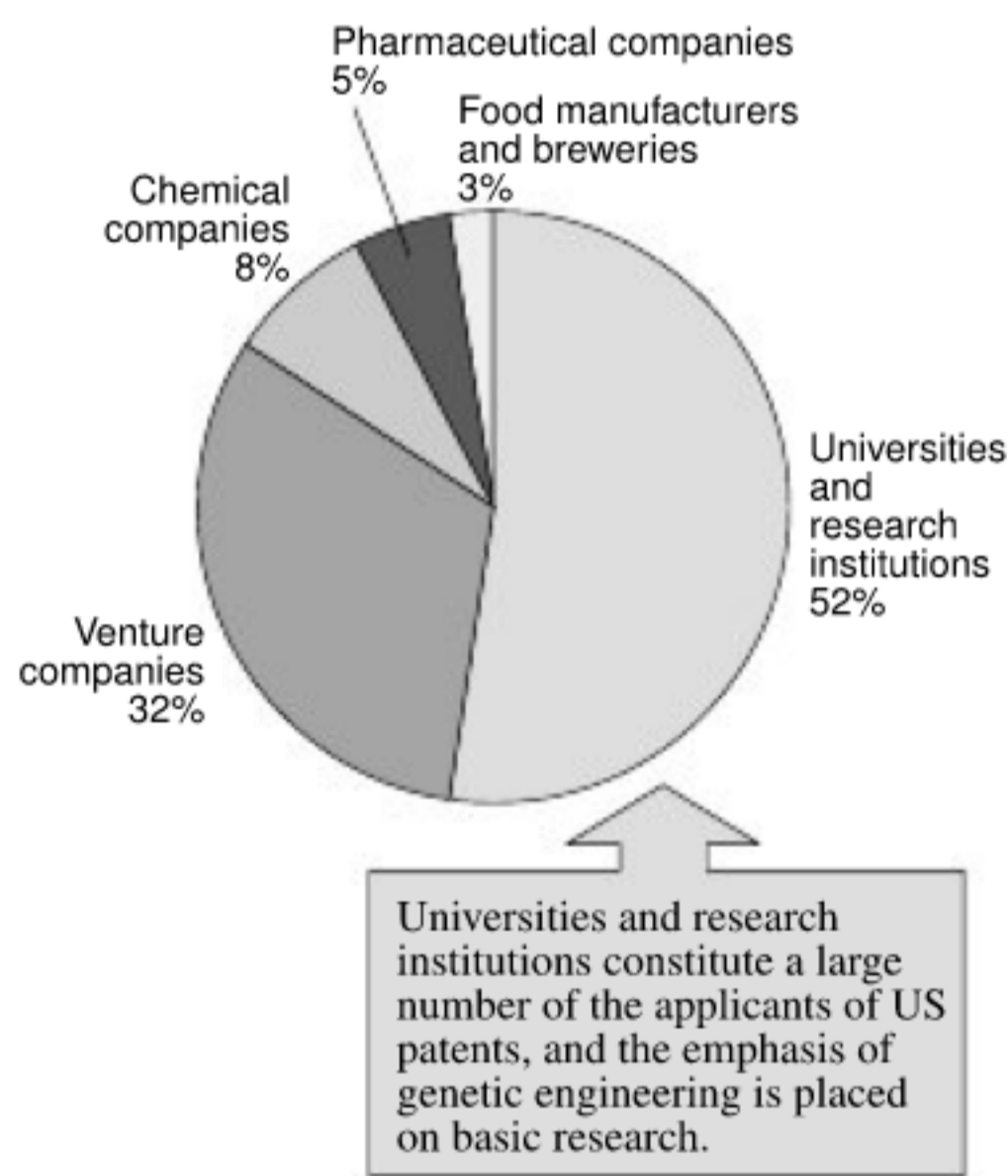

**Fig. 47 Ratio of applicants by country related to genetic engineering**

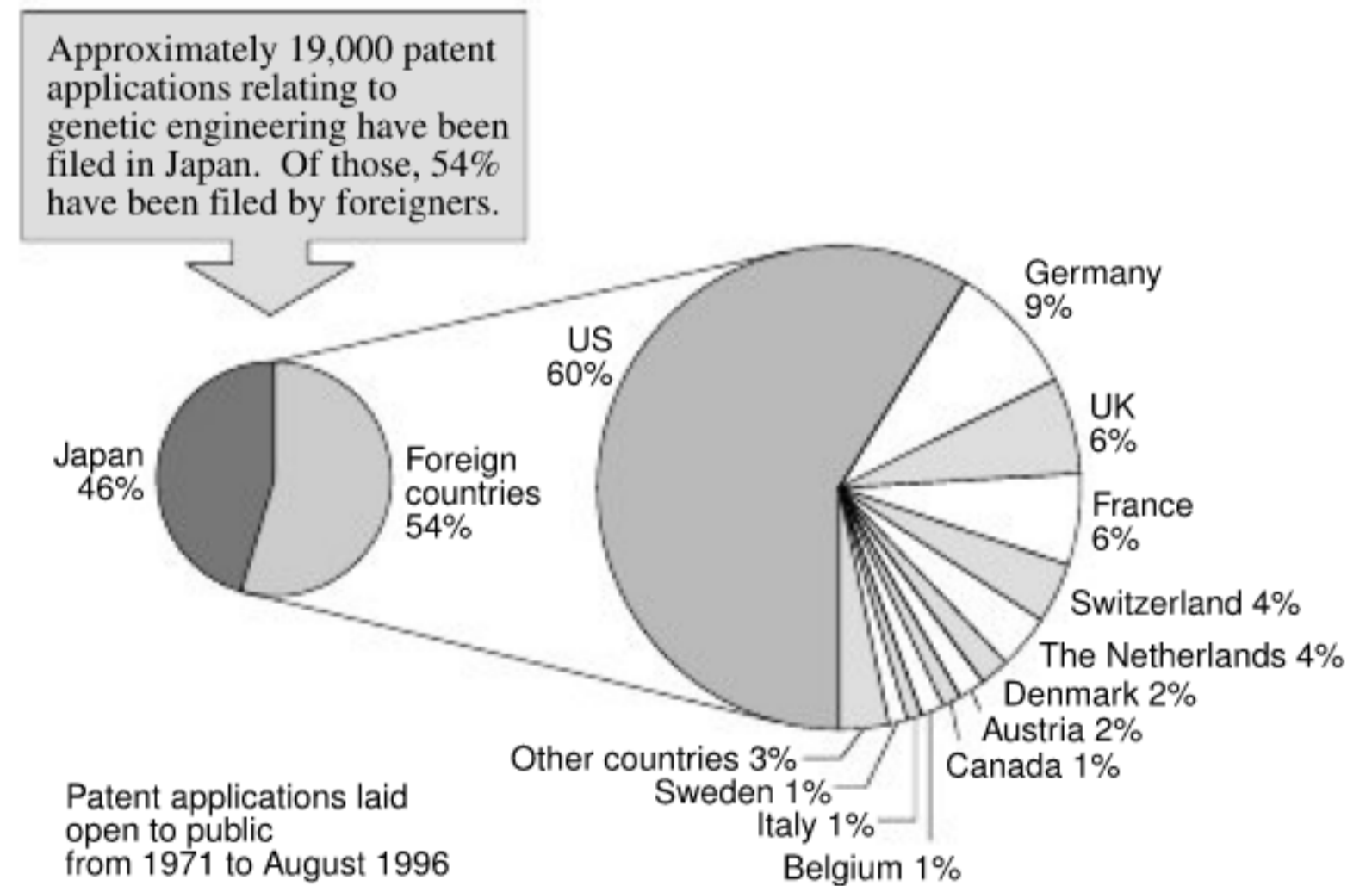

**Fig. 48 Changes in the number of patent applications versus the number of applicants related to genetic engineering**

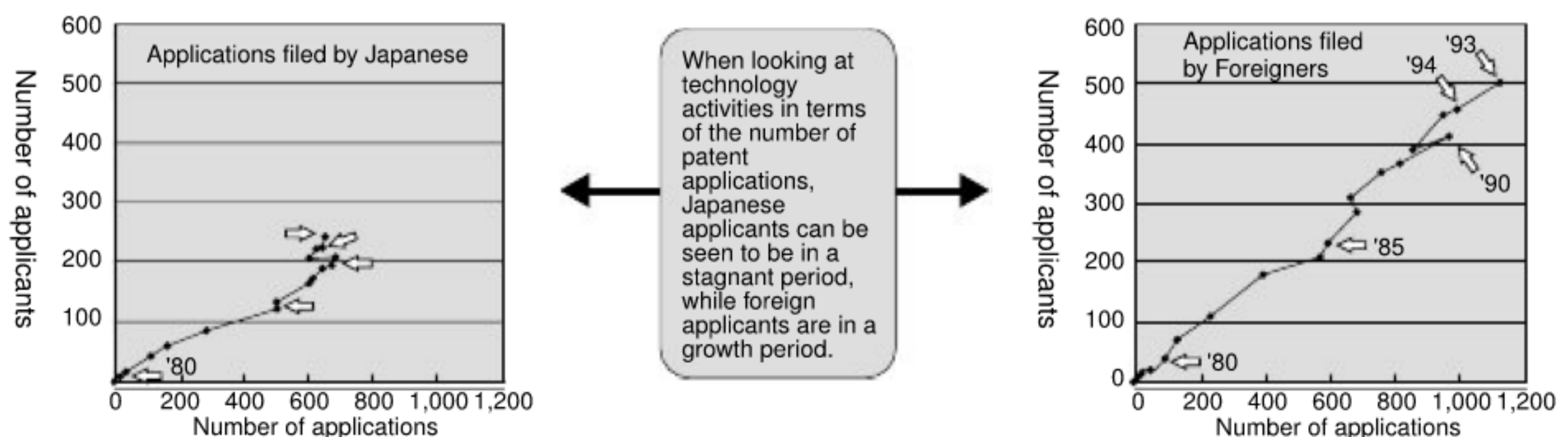

### **III. The Patent Maps Produced by Technology Field**

Fiscal 1997 to fiscal 1999

#### **Technology for adjusting metropolitan environment**

Concrete additive (Chemical 2), Wall material (General 5), Present concrete products (General 11), Earthquake-proof structures and devices (General 13)

#### **Environmental technology**

Incinerator technology (Machinery 6), Industrial micro biology (Chemistry 13), Functional plastics (Chemistry 18), Solid industrial wastes treatment (General 3), Waste water treatment (General 8), Organic waste treatment (General 9), Environment measurement (General 12), Dioxins reducing technology (General 14)

#### **Information and communication technology**

Infrared sensor and its applications (Electricity 1), Image recognition technology (Electricity 2), IC card (Electricity 3), Printed wiring board (Electricity 4), Cellular phone and its applications (Electricity 5), Liquid crystal (Electricity 7), CAD & CAM (Electricity 8), Local area network (Electricity 11), Optical disc (Electricity 13), Video compression (Electricity 14), Optical circuit device (Electricity 16), Central processing unit (CPU) (Electricity 17), Programmable display (Electricity 18), Electronic commerce and financial business (Electricity 19), Organic electroluminescence (Chemistry 14)

#### **Health care and welfare technology**

Immuno-technology and biomedicine (Chemistry 11), Equipment utilized for welfare (General 1), Medical and diagnostic instruments (General 4), Therapeutic and surgical equipment (General 10)

#### **Basic technology**

Programed control (Electricity 9), Semiconductor laser (Electricity 10),

Superconductor (Electricity 12), Industrial cleaning technology (Machinery 1), Engineering ceramics (Chemistry 3), Resin components for paints (Chemistry 7)

### **Products technology**

Structure of general brakes (Machinery 2), DC motor (Machinery 6),  
Electric driving valve (Machinery 5), Industrial robot (Machinery 8),  
Bicycle (Machinery 9)

### **Manufacturing technology**

Arc welding technology (Machinery 3), Manufacturing products by metal processing (Machinery 4), Mold for injection molding (Machinery 7),  
Laser beam machining (Machinery 11), Wood working (Machinery 13),  
Grinding and abrasive machining technology (Machinery 15), Electric plating technology (Chemistry 5), Plastic extrusion (Chemistry 6), Molding (Chemistry 8), Heat treatment (Chemistry 9), Textile modifications (Chemistry 15), Physical vapor deposition (Chemistry 16), Dyeing and processing technology (General 2), Food preservation (General 7)

### **Circulation and distribution technology**

Paper containers (carton box (Machinery 10), Automatic vehicles & hand trucks (Machinery 14)

### **Energy-related technology**

Secondary battery (Electricity 15), Use of solar heat (Machinery 12),  
Solar battery (Chemistry 4)

### **Biotechnology**

Enzyme utilization technology (Chemistry 1), Genetic engineering (Chemistry 10), Genomics & combinatorial chemistry (Chemistry 12),  
Industrial cell biology (Chemistry 17), Breeding (General 6)

## Glossary of Terms

\* **Industrial Property Digital Library (IPDL)**

The Industrial Property Digital Library provides a database of patent information retained by the Japan Patent Office along with a search system that can be accessed over the Internet. The Industrial Property Digital Library service is available for the purpose of making perusal of publication documents available to a wide range of persons as a shared asset of society. The contents provided by the Industrial Property Digital Library consist of the accumulation of approximately 40 million cases of patent information, including examined publication documents relating to patents, utility models, designs and trademarks published by the Patent Office dating back to the Meiji period, as well as examination process information enabling confirmation of the examination status of individual applications.

\* **International Patent Classification (IPC)**

IPC refers to an internationally standardized patent classification that indicates the technical contents of an invention.

\* **File Index (FI)**

FI refers to the classification used for the editing of search files by examiners of the Japan Patent Office, and is a more detailed expansion of the IPC. FI is represented with an IPC symbol and one letter of the alphabet, or with an IPC symbol, three numbers and one letter of the alphabet.

\* **F Term**

F Term was developed for searching for examination reference materials by examiners of the Patent Office, and F Term symbols have been assigned to approximately 2,200 technical fields. F Term provides a multiple view point breakdown of technical contents and application fields for technologies for which classifications in the literature are insufficient in the case of FI expansion.

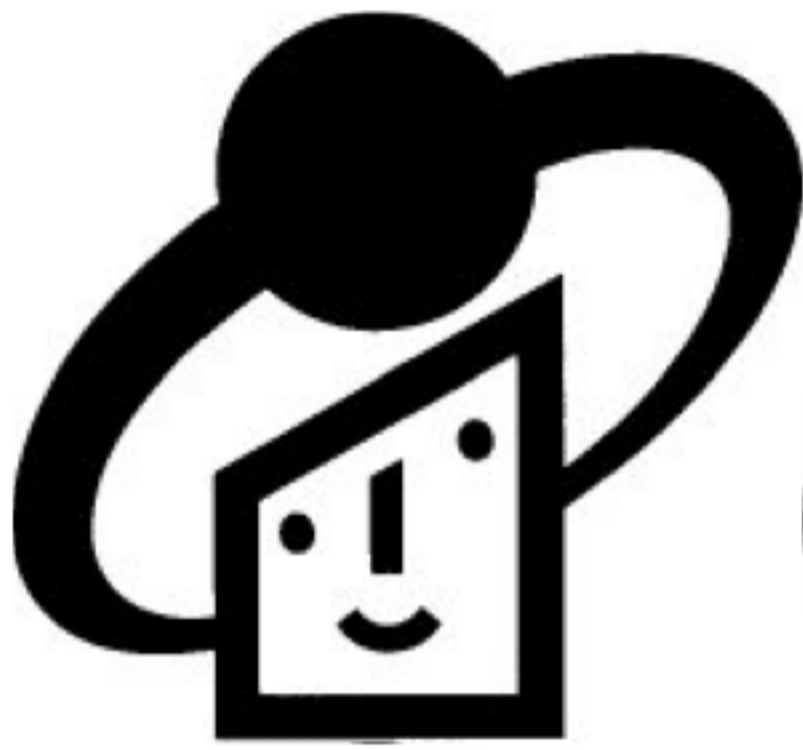

**Patemaru-kun**

The trademark of the Japanese industrial property right system

**Japan Patent Office**

Address: 3-4-3, Kasumigaseki, Chiyoda-ku,  
Tokyo, 100-8915, Japan

**Asia-Pacific Industrial Property Center  
of Japan Institute of Invention and Innovation**

Address: 3-4-2, Kasumigaseki, Chiyoda-ku,  
Tokyo, 100-0013, Japan